

Boston Mk.III 'Intruder'

EN

Americké letectvo usoudilo v roce 1937, že jednomotorové letouny kategorie Attack přestávají výkonově stačit. Vypsalo proto soutěž na nový dvoumotorový stroj této kategorie. Firma Douglas se stala vítězem této soutěže se svým návrhem model 7B. Původní návrh by postupně upravován, částečně také podle francouzských požadavků. Francie a další evropské země objednaly stroje označované DB-7A. Všechny tyto stroje byly poháněny motory R-1830. Po kapitulaci Francie převzalo další objednávky RAF. RAF tyto stroje pojmenovalo Boston Mk.I. USAF a RAF požadovaly větší výkony a tak firma Douglas navrhla model DB-7B se silnějšími motory R-2600. Americké letectvo dostalo nejprve malou sérii A-20A Havoc s motory vybavenými turbokompresory a pak velké série verzí A-20B a A-20C. Ty se lišily zejména tvarem prosklení přídě. A-20B měla prosklení stupňené, A-20C šikmé. Tyto stroje odebralo i RAF, které přidělilo verzi A-20B jméno Boston Mk.III a verzi A-20C Boston Mk.IIIA. Dále se tyto stroje dostaly do výzbroje SAAF, RAAF (ex holandské stroje pro Holandskou východní Indii) a Brazílie. V rámci Lend-Lease je dostal i Sovětský svaz. Na základě těchto strojů byly postaveny i noční stíhací verze, americká P-70 a britská Havoc NF Mk.II. Část britských strojů byla přestavěna na variantu Havoc Turbinlite se světlometem v přídí a neúspěšně použita k nočnímu stíhání.

A-20B/C se jako lehké bombardéry a bitevníky velmi osvědčily. USAF je nasadilo hlavně v Africe a Itálii, Britské RAF s Bostony zahájilo tzv. Non-stop ofenzívu, používalo je jako denní bombardéry i k nočním útokům na nepřátelská letiště a jiné cíle (Intrudery). Část strojů nasadilo také v Africe a Itálii. Australské RAAF upravilo své Bostony montáží pevných zbraní do přídí a nasadilo je s velkými úspěchy k bitevním útokům z malých výšek. Dalším vývojem vznikly verze A-20G/H/J/K vyzbrojené střeleckou věží místo hřbetního střeliště. Ty sloužily až do konce druhé světové války. Rozpětí: 18,69 m, délka: 14,27 m, max. rychlost: 560 km/h, dolet: 1 740 km, dostup: 8 800 m., nosnost pum: 940 kg, obranná výzbroj se lišila dle provedení pro USAF nebo RAF.

CZ

In 1937 US Air Force HQ found out that single engined Attack aircrafts' performances are not sufficient. Therefore a competition was issued calling for new twin engined aircraft of the latter category. Douglas Co. won this competition with its Model 7B design. The original design was subsequently modified, partly according to the French requirements, too. France and other European countries had ordered these machines under designation DB7A. All these machines were powered by R-1830 engines. When the France had capitulated the rest orders were taken over by RAF that designated these machines as Boston Mk.I. Both RAF and USAF had demanded better performances so Douglas Co. designed Model DB-7B powered by R-2600 engines with better output. First off USAF received small batch of A-20A Havocs powered by engines with superchargers and then bigger series of A-20B and A-20C. These versions differed from each other mainly by the nose glazing shape. A-20B had step like glazing but A-20C featured diagonal edge of the glazing. Both versions were also ordered by RAF that designated them Boston Mk.III and Mk.IIIA respectively. Moreover, these machines were used by SAAF and RAAF (ex-dutch machines foe Dutch East India AF) and Brazil. As a part of the Lend-Lease treaty, also Soviet Union received these machines. Based on these versions the night fighter version, US P-70 and British Havoc NF Mk.II were built. Several British machines were modified into Havoc Turbinlite equipped with searchlight in nose for night fighter missions but without success. A-20B/C proved efficient as light bombers and attack planes. USAF deployed them mainly to Africa and Italy, RAF started with Bostons the so-called Non-Stop offensive; they were used as day bombers and night Intruder missions against enemy airbases and other targets. Several machines were also deployed to Africa and Italy. Australian RAAF modified its Bostons by addition of fixed machineguns into nose and successfully used them as ground attack planes. Further development brought versions A-20G/H/J/K equipped with dorsal turret in place of the original dorsal gunner's position. These versions served until the end of the World War 2.

Wingspan: 18.69 m, length: 14.27 m, max. speed: 560 km/h, range: 1,740 km, service ceiling: 8,800 m., bomb load: 940 Kg; both USAF and RAF versions differed by defensive armament.

PARTS LIST 1/2

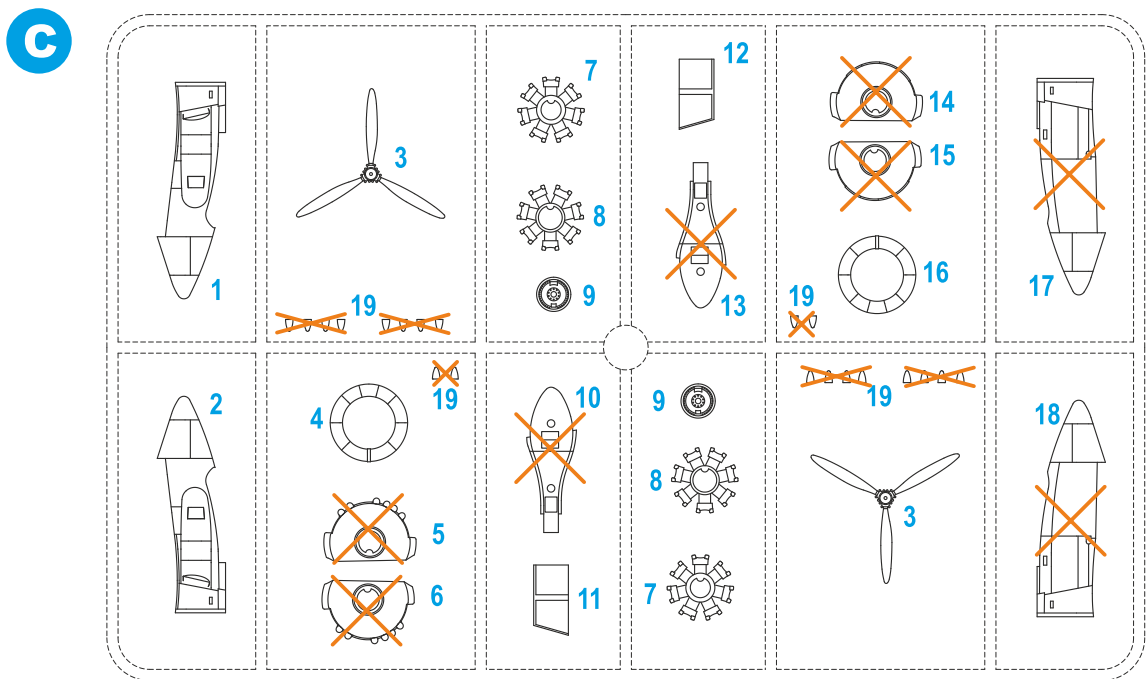
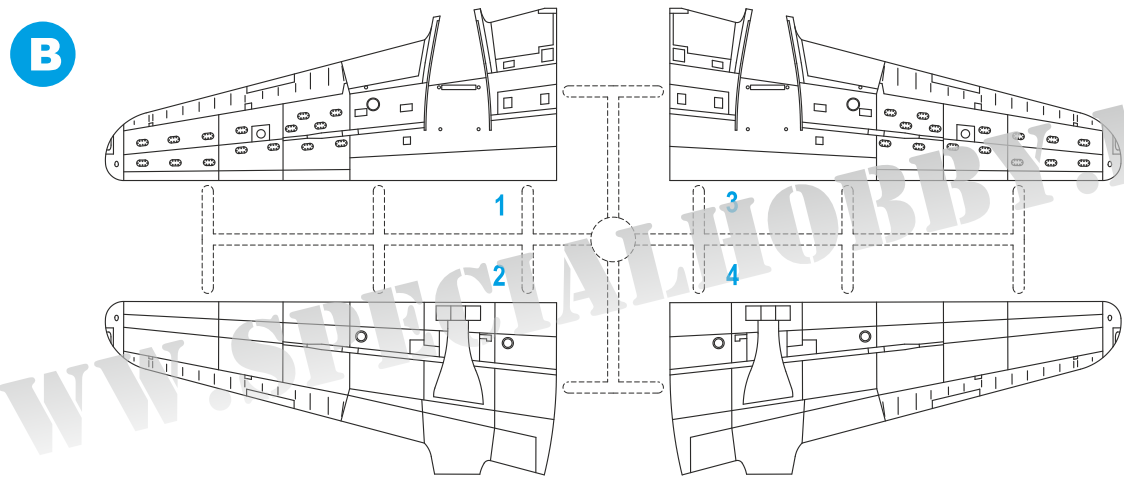
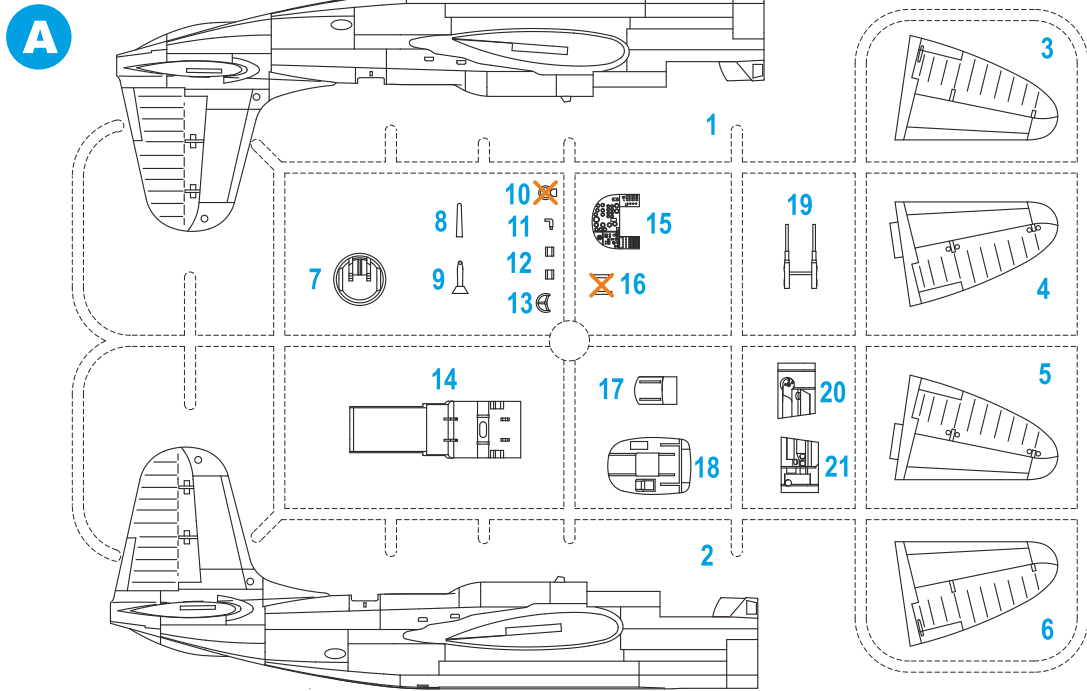

not to be used

PARTS LIST 2/2

I

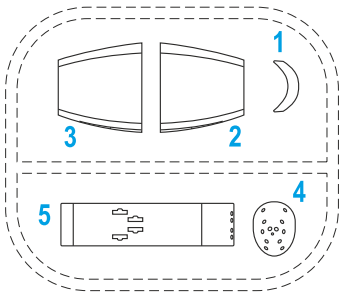

D

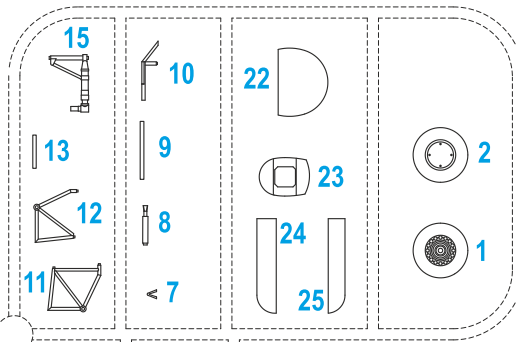

L

CLEAR PARTS

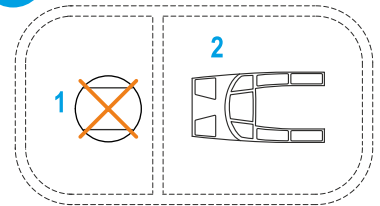

K

CLEAR PARTS

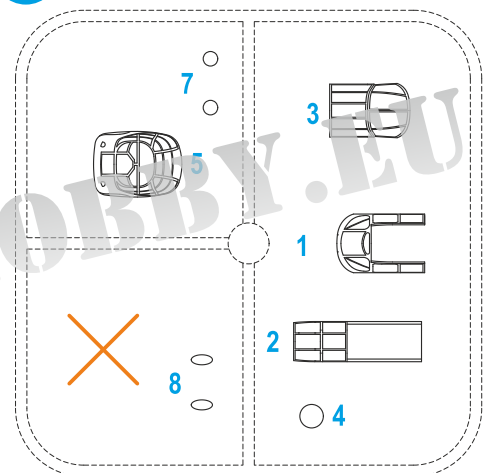

G

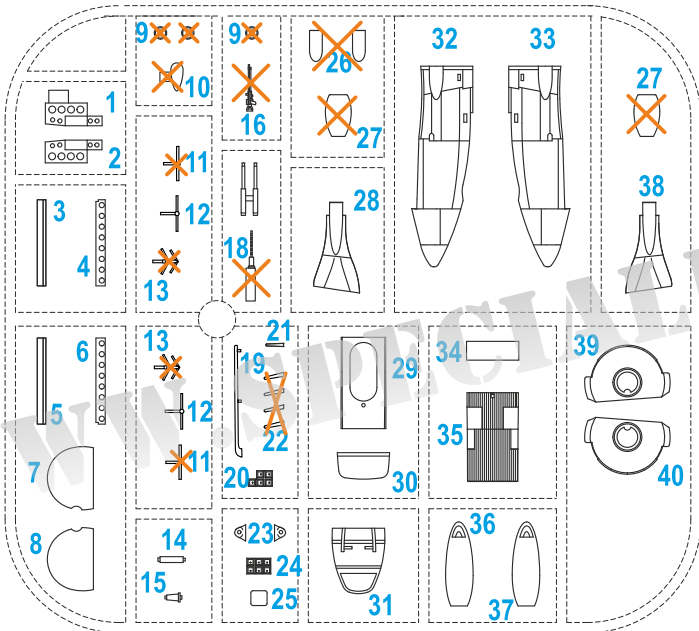

POLYURETHAN PARTS (PUR)

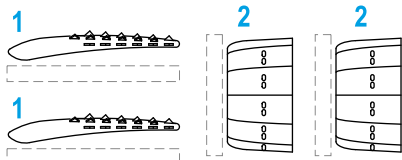

PHOTO-ETCHED PARTS (PP)



not to be used

Barvy GUNZE/ GUNZE Colour No.

A	Flat Black / černá matná	H12/C33
B	Aluminium / hliník	H8/C8
C	Interior Green / zelená interiér.	H57/C27
D	Burnt Metal / opálený kov	H61/C76
E	Tire Black / barva pneu	H77/C137
F	Dark Iron / tmavý kov	MC214
G	Grayish Blue / modrošedá	H337/C337
H	Clear Red / červená čirá	H90/C47
I	Clear Green / zelená čirá	H94/C138



OPTIONAL
MOŽNOST VOLBY
NACH BELIEBEN
OPTION



INSTANT CYANOACRYLATE GLUE
POUŽIT KYANOAKRYLÁTOVÉ LEPIDLO
ZYANOAKRYLÄTKLEBER
ADHÉSIF CYANOACRYLAT

SYMBOLS



BEND
OHNOUT
BIEGEN
COURBER



SCRATCH BUILD
ZHOTOVIT NOVÉ
FERTIGSTELLEN
ACHEVER



CUT OFF/DRILL
ŘEZAT/VRTAT
ENTFERNEN
DETACHER

GSI **A**
colours code

COLOUR
NATRÍT
FARBEN
PEINDRE

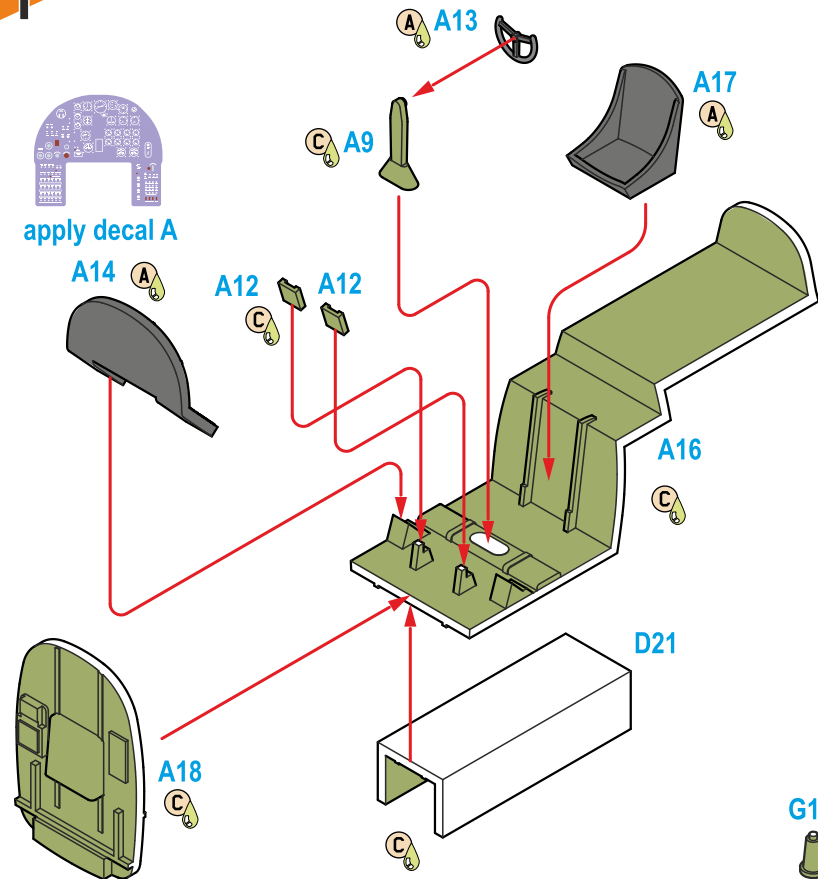
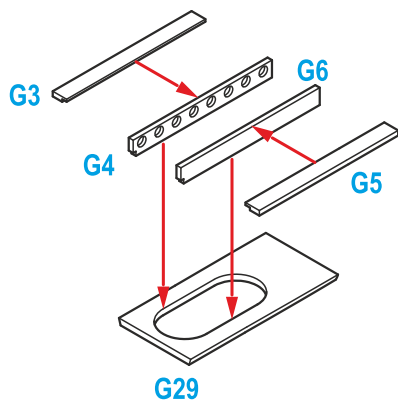
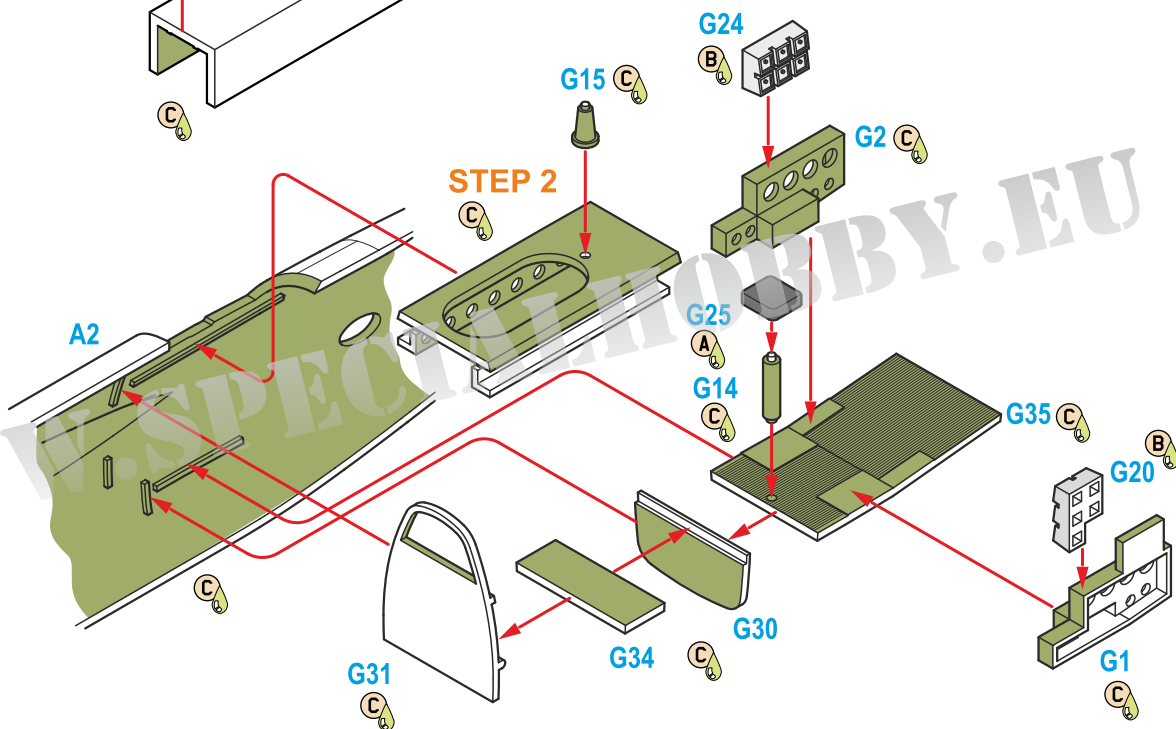
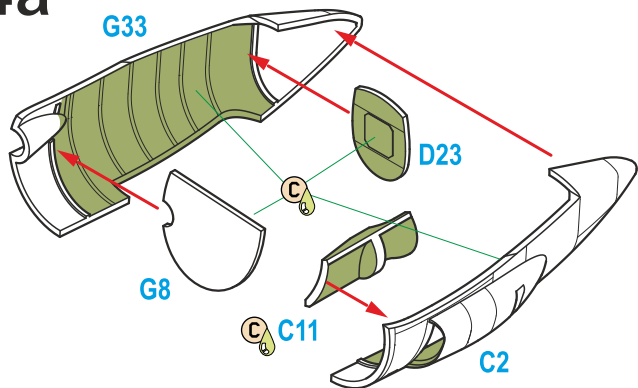
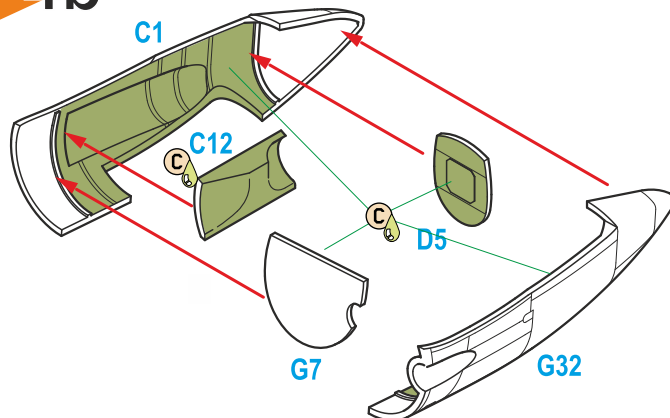
1**2****3****4a****4b**

5

Carefully clean parts A20 and A21 so they fit in recesses in the fuselage halves.
Cut the corner of part A21 according to the drawing.

Díly A19 a A20 pečlivě začistěte a vlepěte tak, aby přesně zapadly do vybrání v polovinách trupu. Na dílu A21 odřízněte roh dle obrázku.

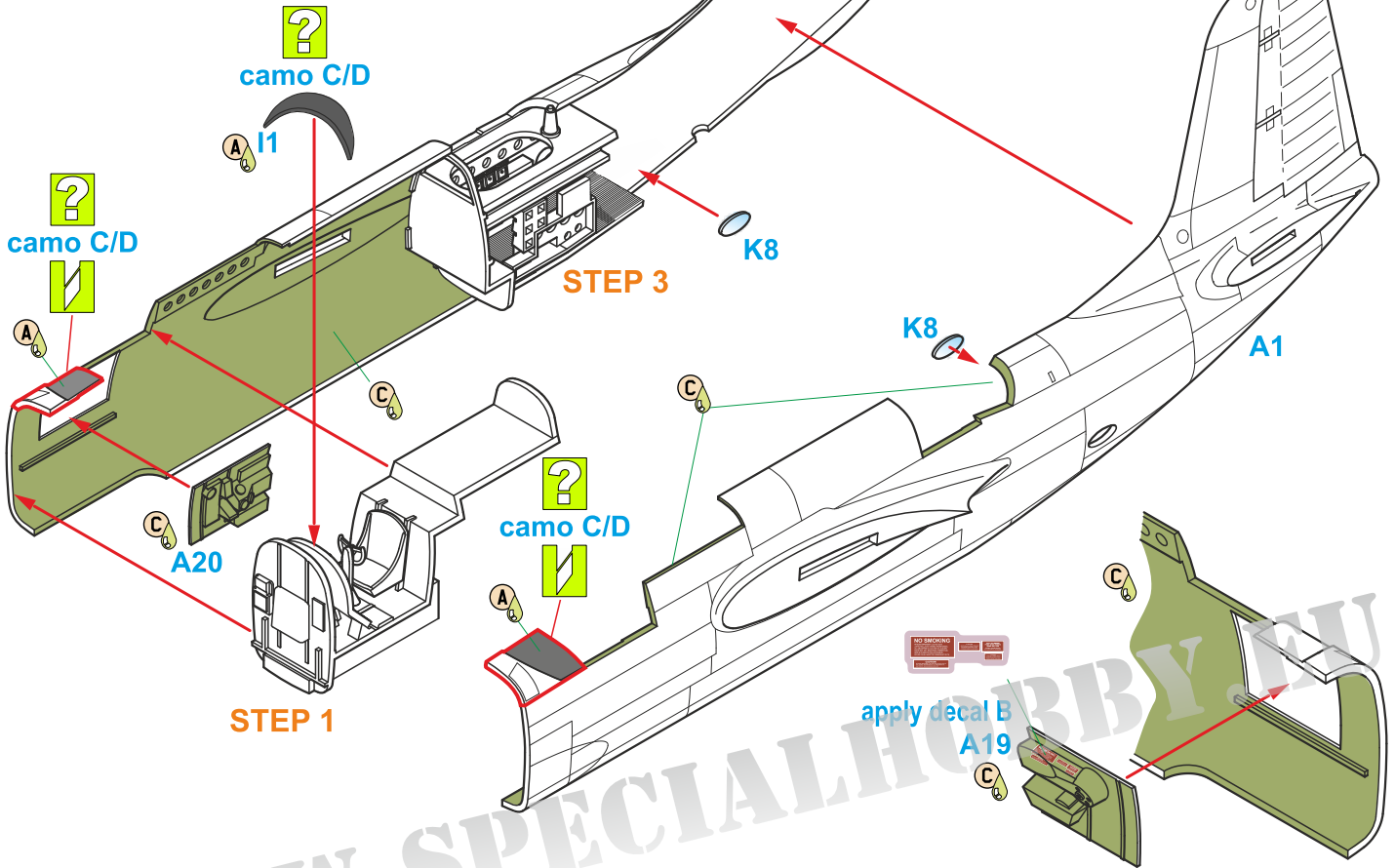
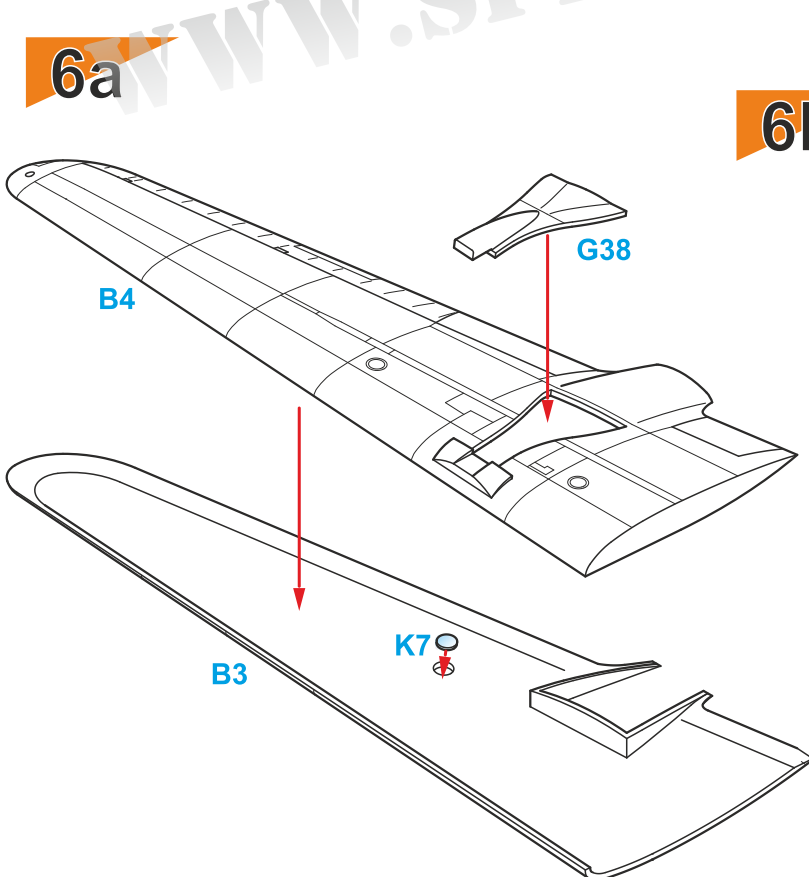
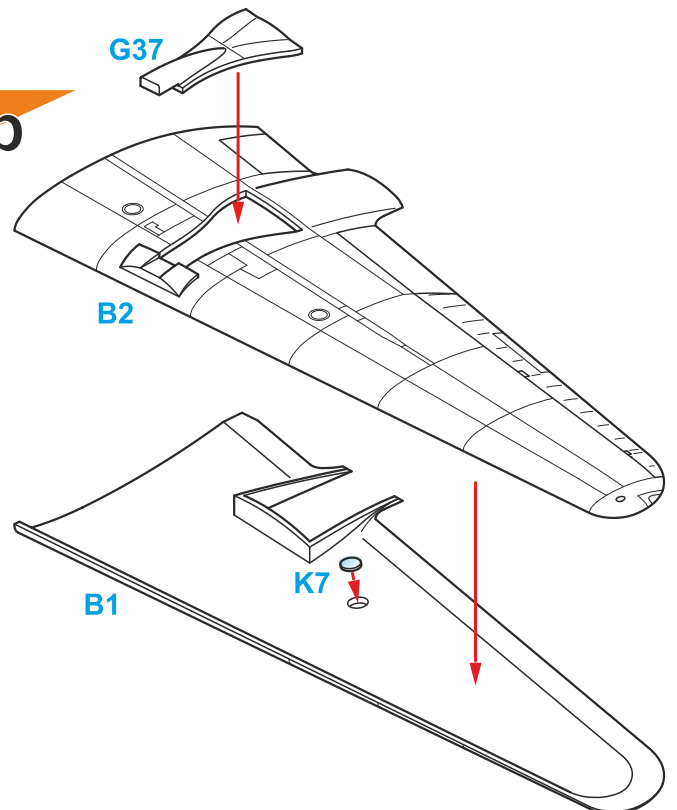
**6a****6b**

7a

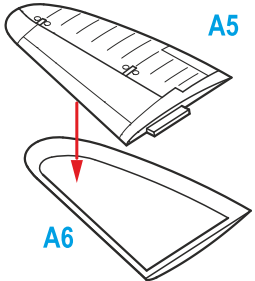

7b

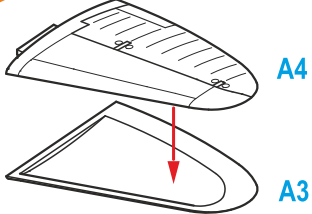

8

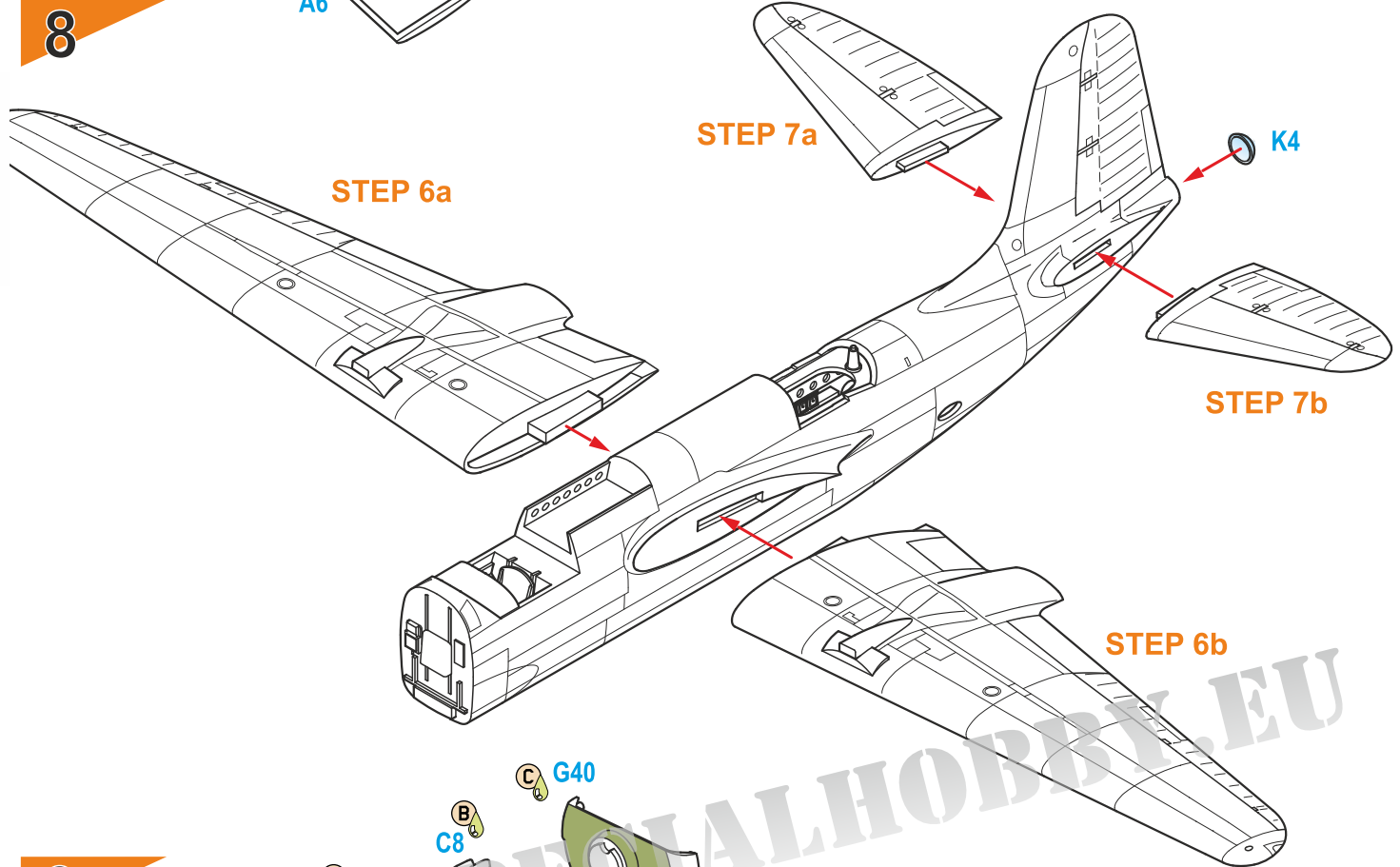

9a

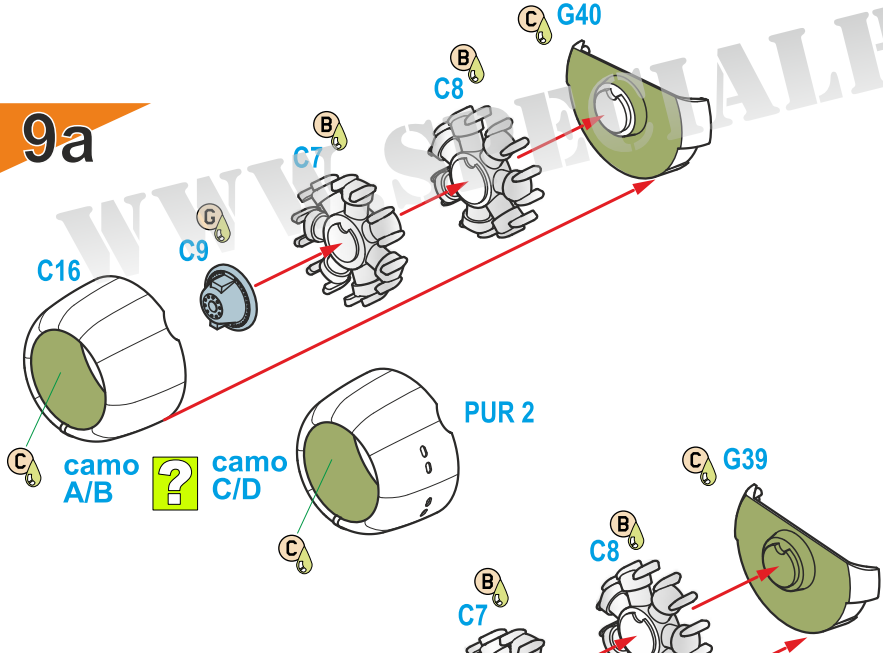

10

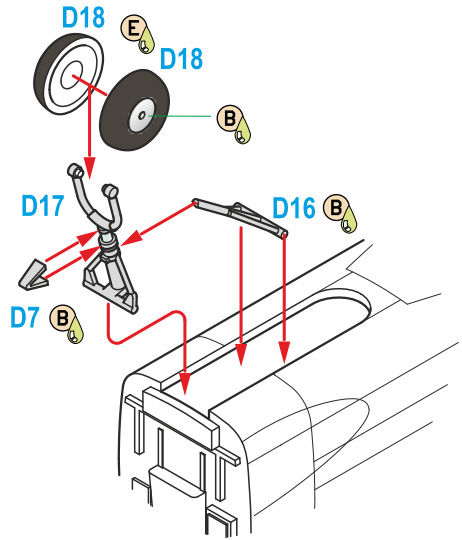

9b

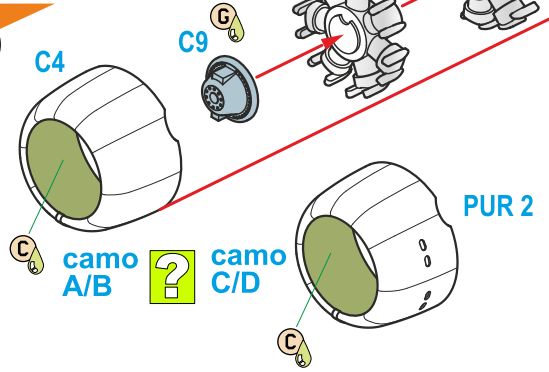

11a

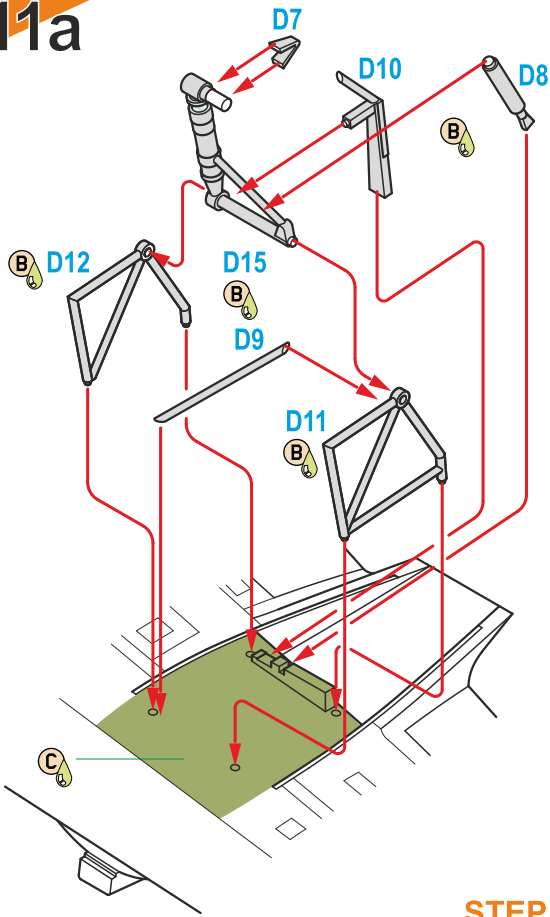

11b

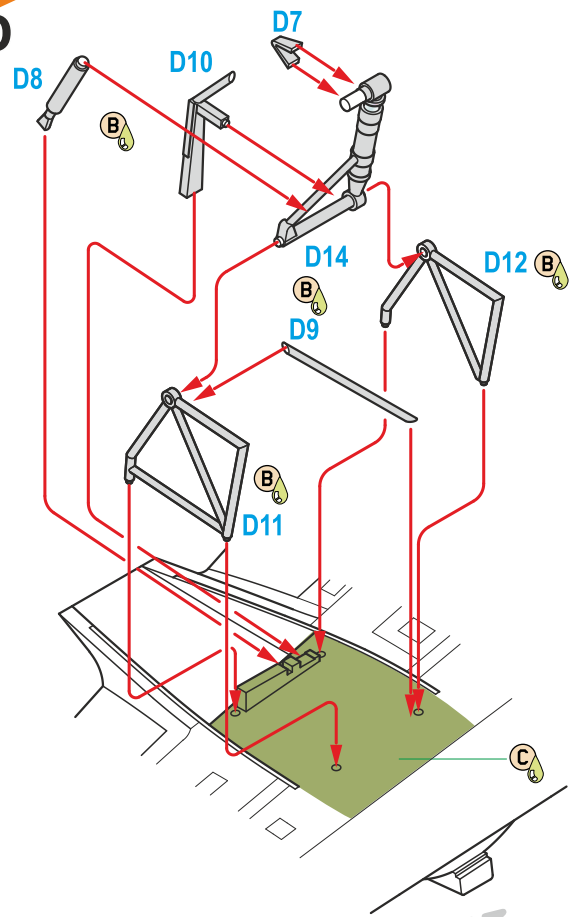

STEP 4a

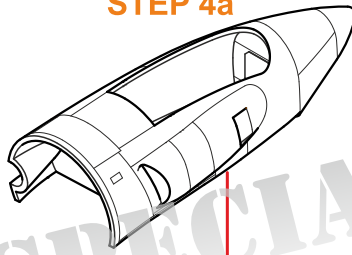

STEP 4b

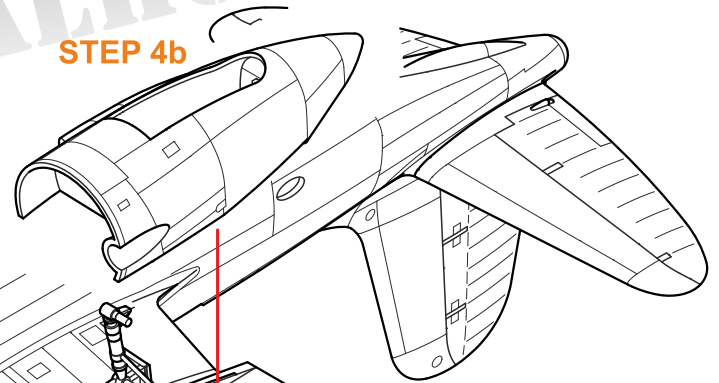

12

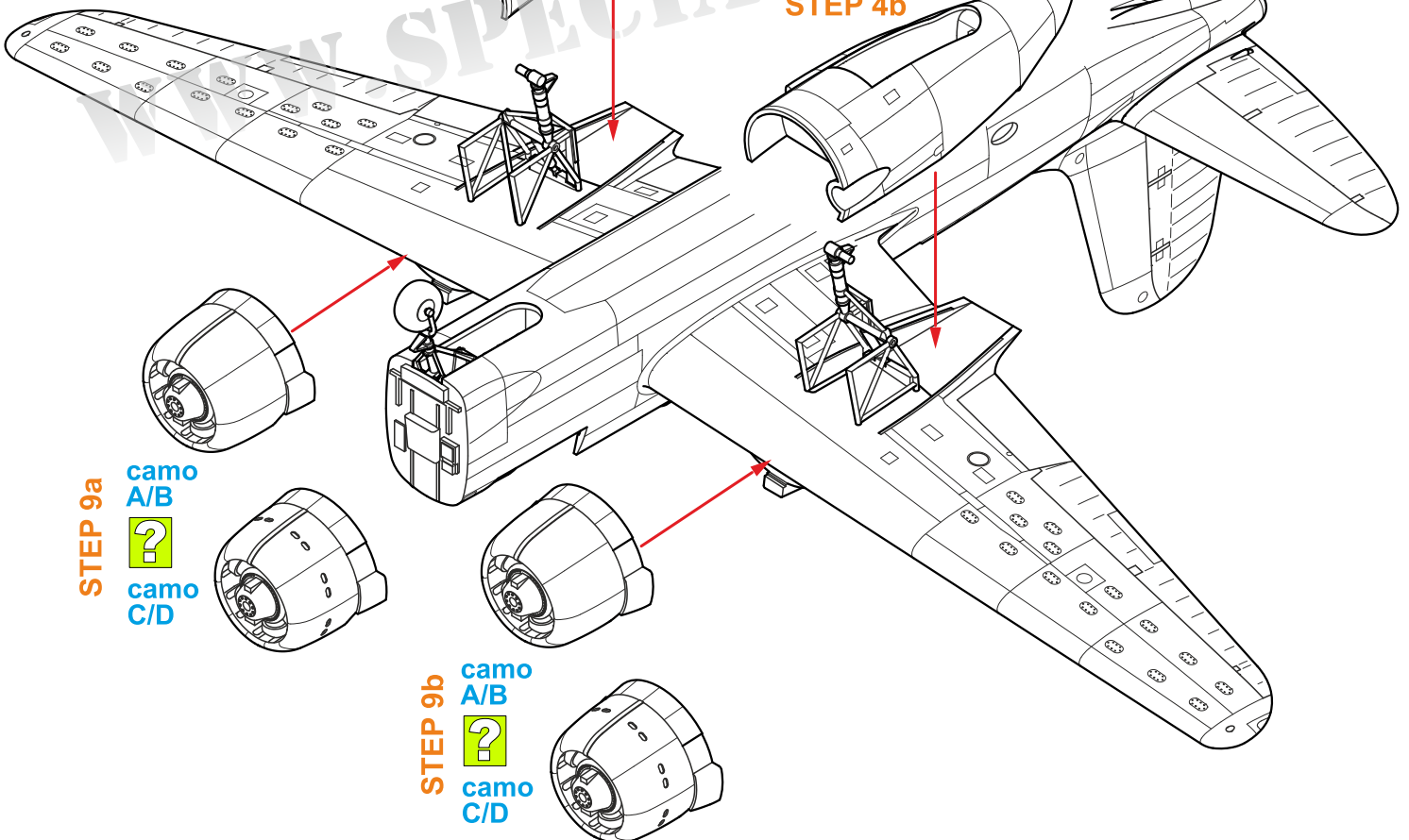

STEP 9a

camo A/B
?
camo C/D

STEP 9b

camo A/B
?
camo C/D

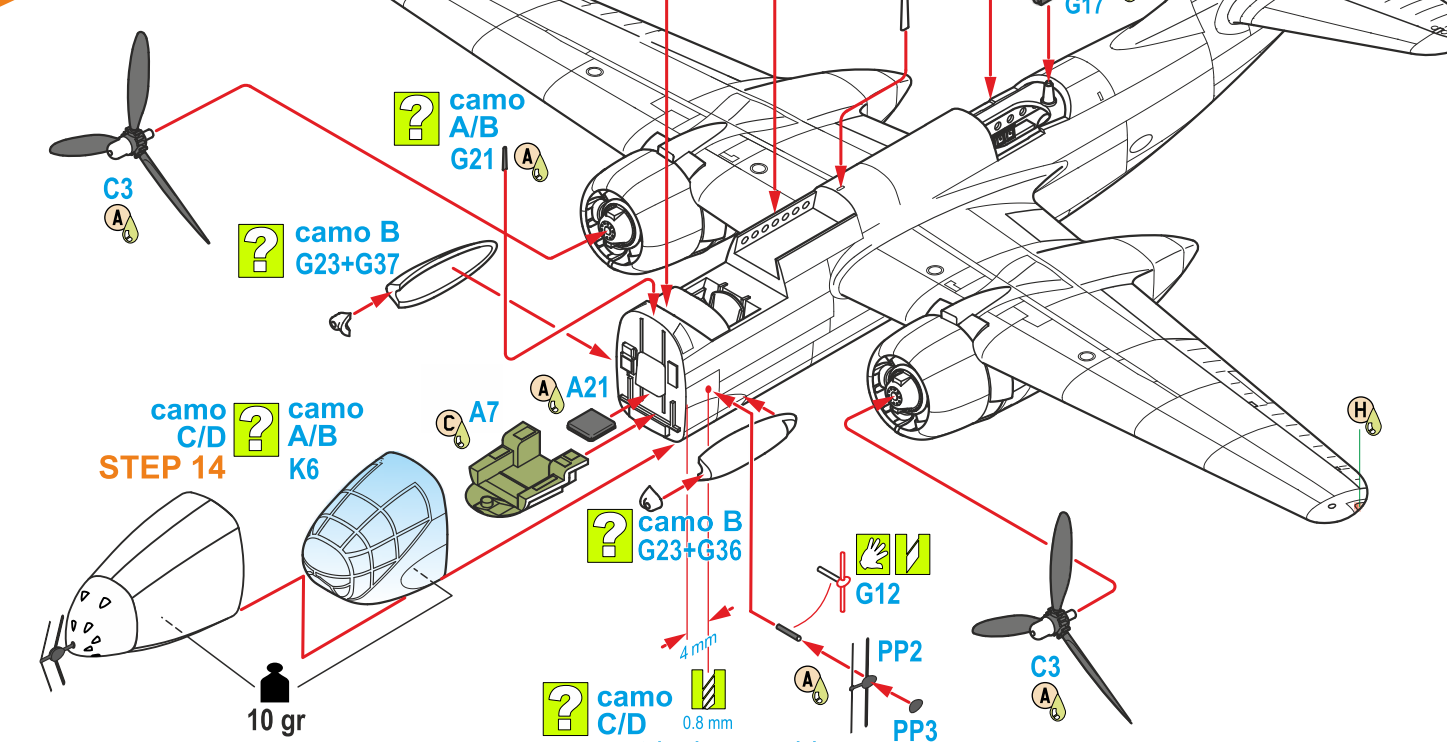
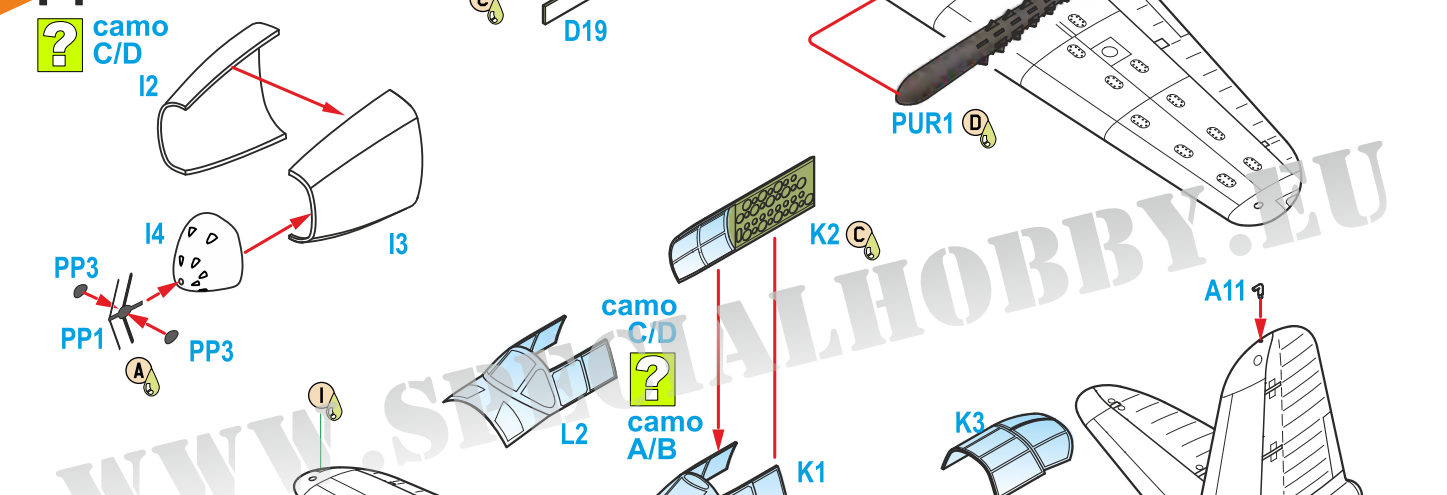
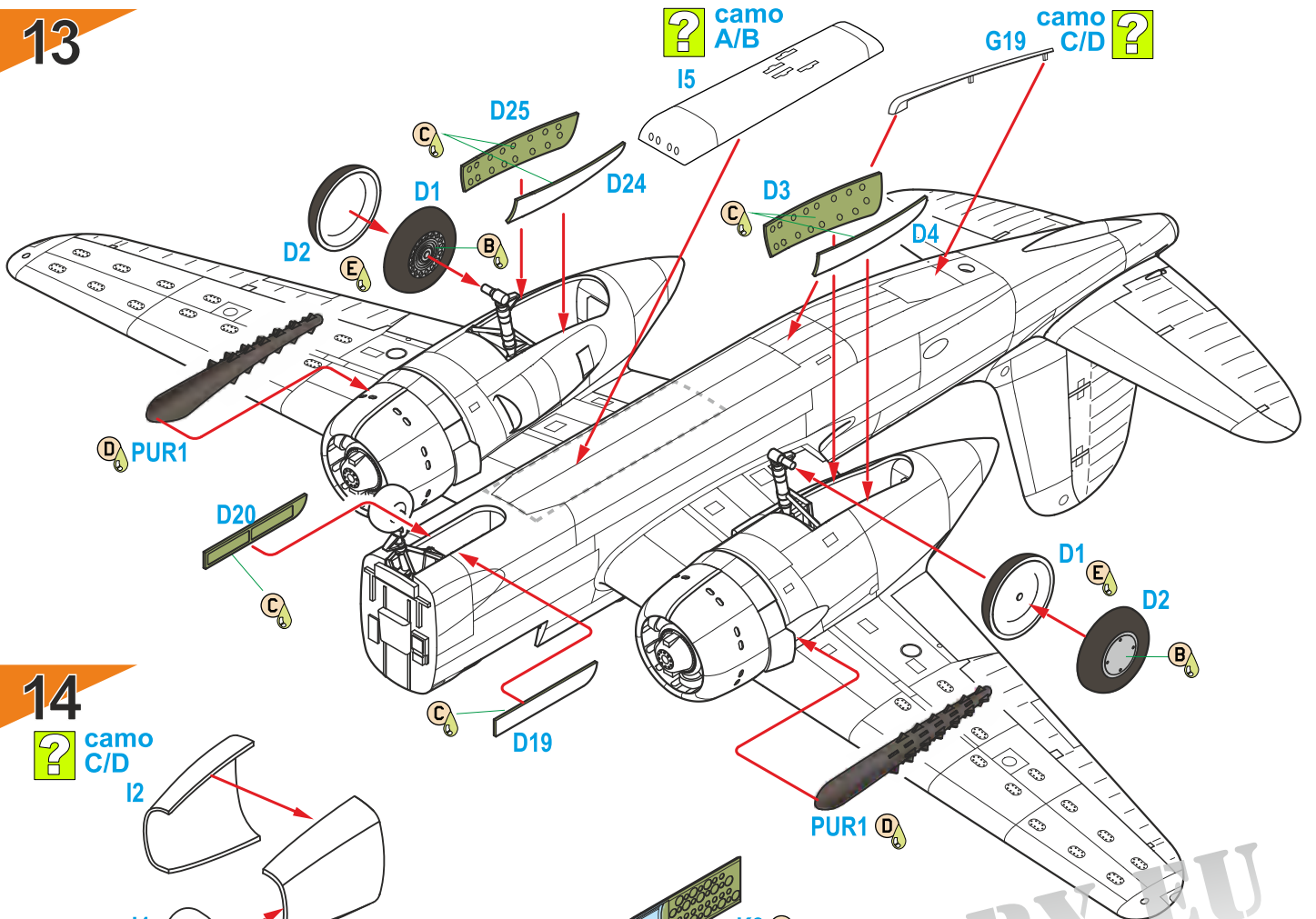

Boston Mk.III 'Intruder', AL468/TH-O, No.418 City of Edmonton Sqn RCAF, Bradwell Bay, December 1942 to June 1943. On the night of 12 April 1943, S/L Burton-Gyles shot down an enemy aircraft over the town of Beauvais. To mark this achievement, a small swastika was painted on the port fuselage underneath the Canadian maple leaf badge.

Boston Mk.III „Intruder“, AL468/TH-O, No. 418 „City of Edmonton“ Squadron RCAF, Bradwell Bay, prosinec 1942 až červen 1943. V tomto letounu sestřelil S/L Burton-Gyles v noci 12. dubna 1943 nepřátelský letoun nad Beauvais. Tento úspěch označovala svastika pod javorovým listem na levé straně trupu.

CAM. A

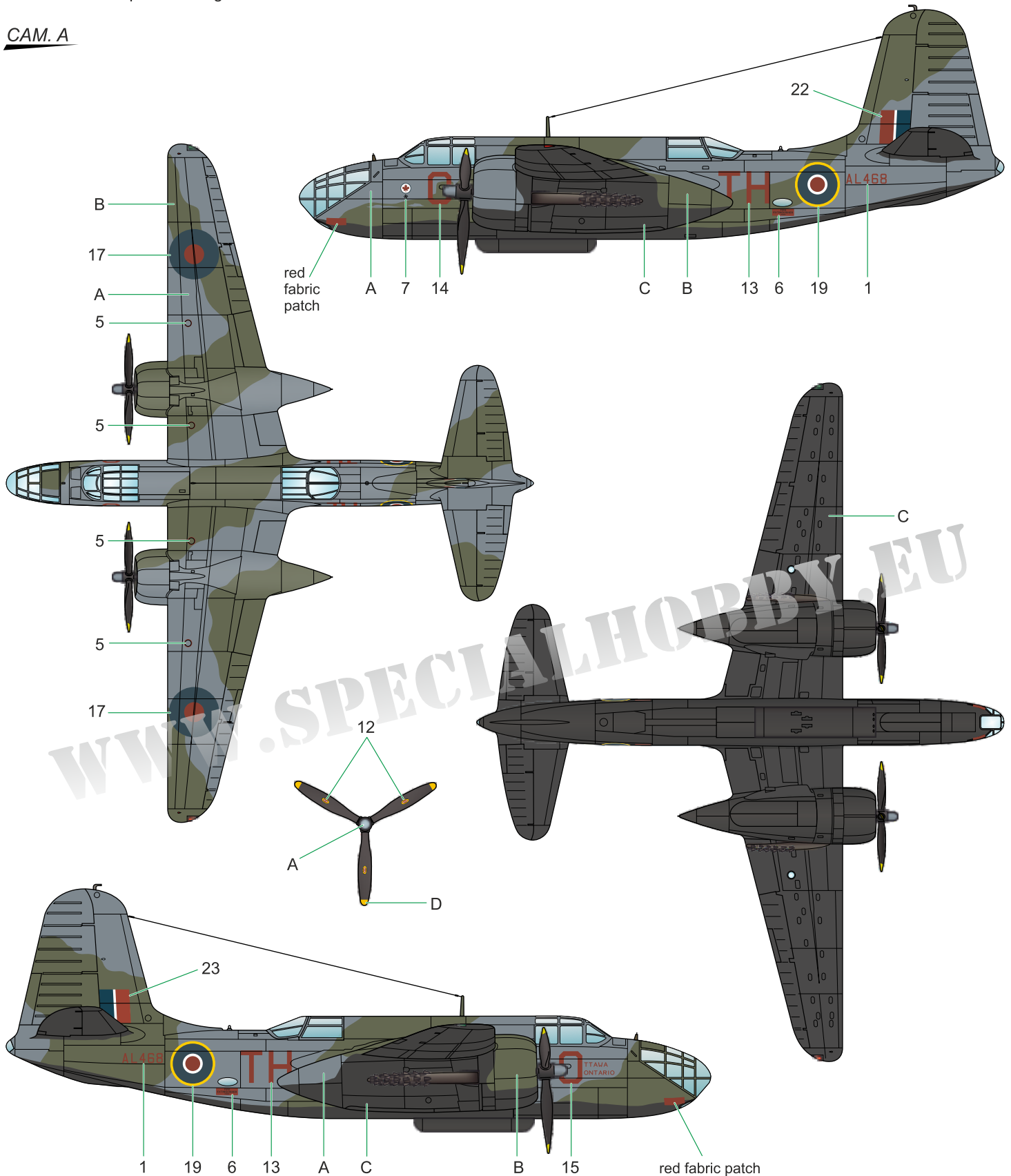

- | | | | |
|-------------------------------------|------------------------------------|---|--------------------------|
| A | B | C | D |
| Ocean Grey
Oceánská šedá
C362 | Dark Green
Tmavě zelená
C361 | Night (Smooth Black)
Noční hladká černá
H12/C33 | Žlutá
Yellow
H4/C4 |



Boston Mk.III 'Intruder', W8295/TH-G, No.418 City of Edmonton Sqn RCAF, Bradwell Bay, early 1943. Overall black machine wore mission markings on its port front fuselage.

Boston Mk.III „Intruder“, W8295/TH-G, No. 418 „City of Edmonton“ Squadron RCAF, Bradwell Bay, začátek roku 1943. Celočerný letoun byl ozdoben symboly misí na leví straně přídě.

CAM. B

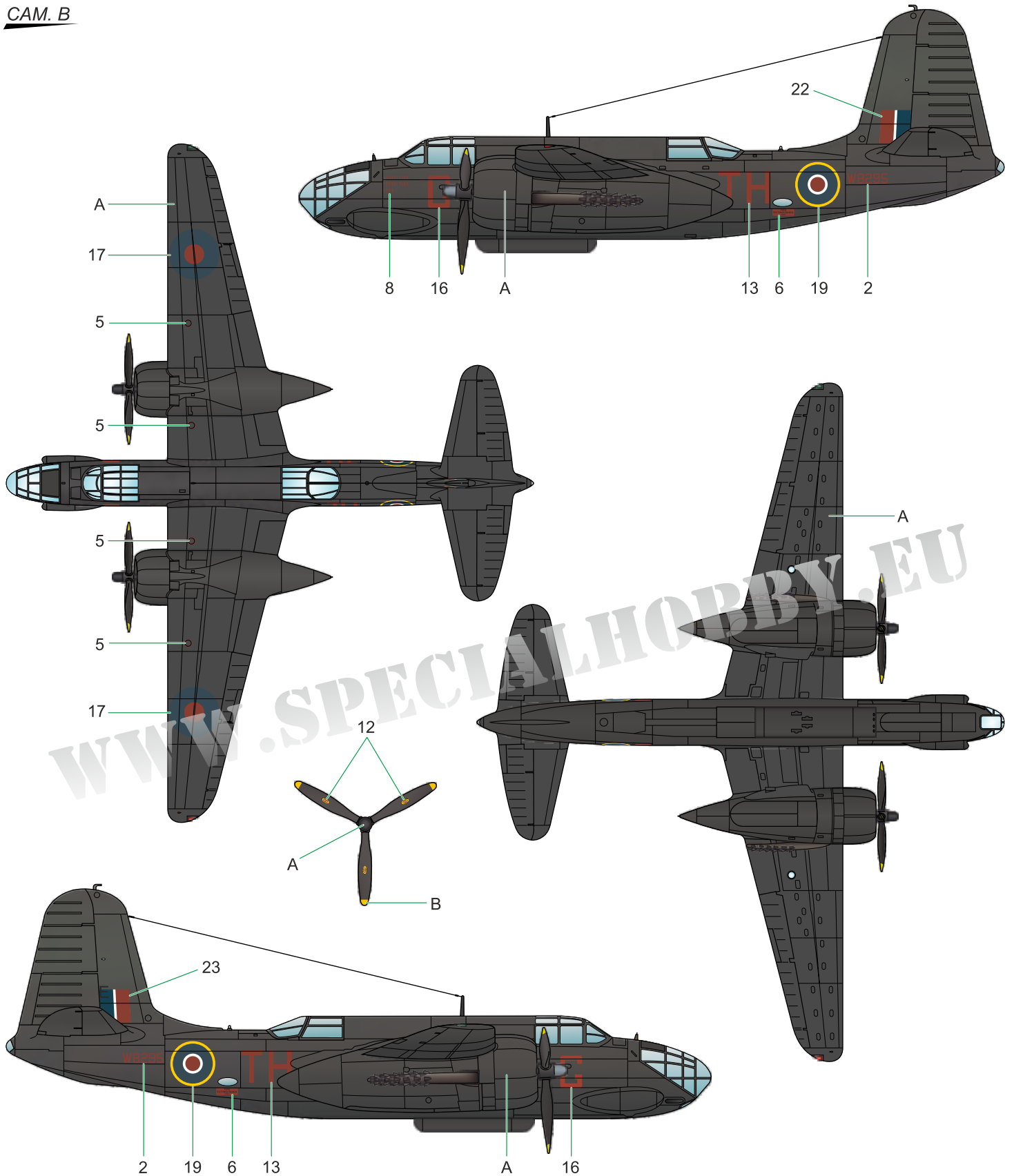

A Special Night Finish RDM.2A
Speciální noční nátěr
H12/C33

B Žlutá
Yellow
H4/C4



Havoc Mk.II, AH523/VY-Z, No.85 Sqn RAF, Hurdson,
August 1941.

Havoc Mk.II, AH523/VY-Z, No.85 Squadron RAF, Hurdson,
srpen 1941.

CAM. C

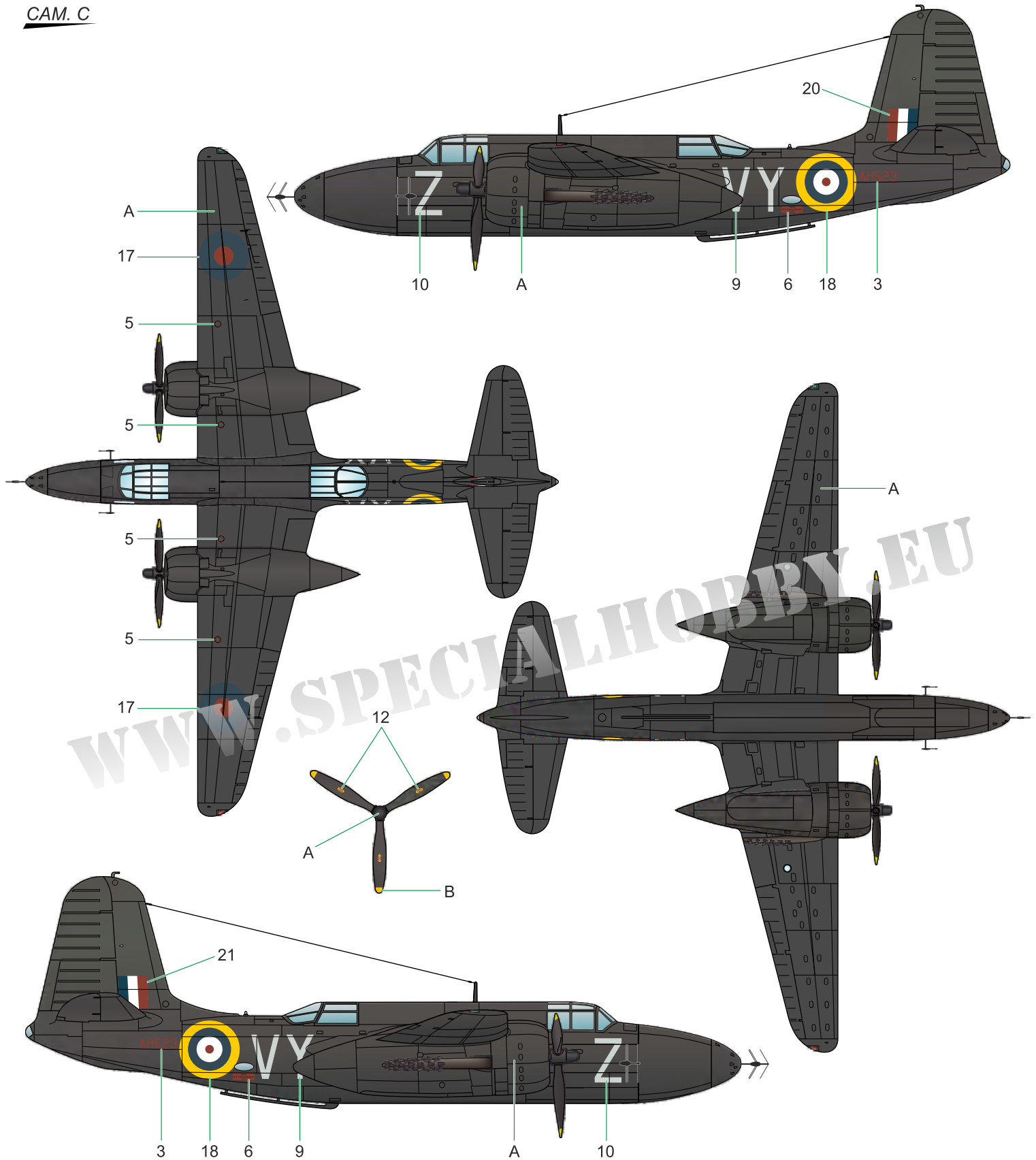

A Special Night Finish RDM.2A
Speciální noční nátěr
H12/C33

B Žlutá
Yellow
H4/C4



Havoc Mk.II, AH520/VY-A, No.85 Sqn RAF, Hurdson,
September to October 1941.

Havoc Mk.II, AH520/VY-A, No.85 Squadron RAF, Hurdson,
září–říjen 1941.

CAM. D

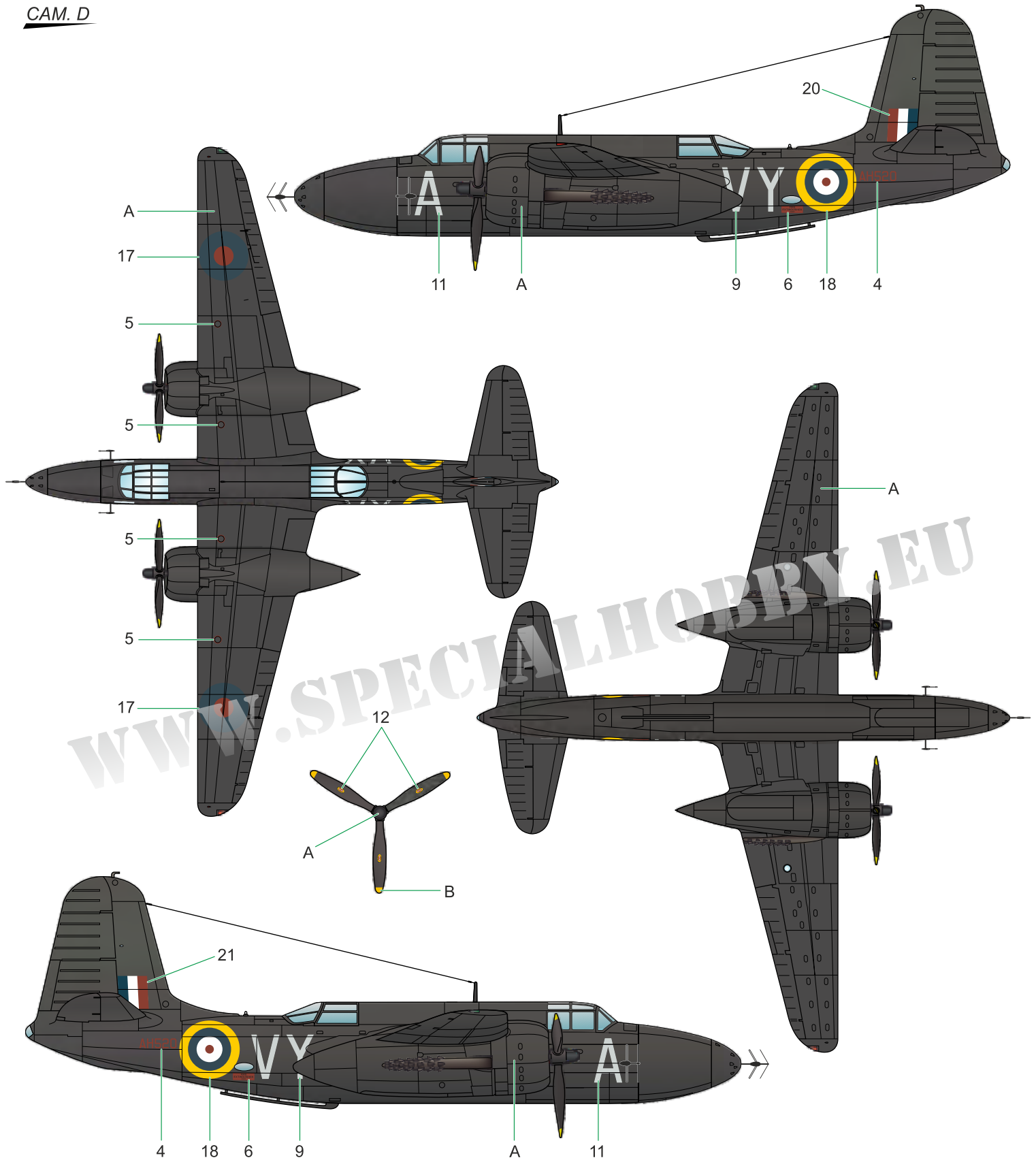

A Special Night Finish RDM.2A
Speciální noční nátěr
H12/C33

B Žlutá
Yellow
H4/C4

