**SH 32006****Morane-Saulnier Type N****1/32****(CZ)**

Morane Saulnier N byl zalétán jako závodní a sportovní letoun v květnu 1914 ještě před vypuknutím První světové války. Prvním veřejným vystoupením bylo letecké setkání na vídeňském letišti Aspern od 21. do 28. června 1914. Zde slavný pilot Roland Garros zvítězil v závodě ve stoupavosti.

Po vypuknutí bojů se s typem N jako s bojovým nepočítalo. Teprve po sestřelení Rollanda Garrose (letěl na typu Morane Saulnier L) jeho přítel Eugene Gilbert nechal vyzbrojit prototyp typu N nesynchronizovaným kulometem Hotchkiss, na vrtuli nechal namontovat deflektory. Vzhledem k úspěšnosti úpravy objednalo Aviation Militaire malou sérii Morane Saulnier N. Sloužily od léta 1915 u několika escadrile. Typ proslavili hlavně piloti Jean Navarre (MS.12) a Adolphe Pegoud (MS.49).

Britské RFC objednalo sérii Morane Saulnier N ozbrojenou kulometem Lewis na začátku roku 1916. Zařadilo je k 1., 3. a 60. squadroně. Stroje se zúčastnily bojů na Sommě a nad Cambrai. Posléze byly staženy pro nedostatek náhradních dílů.

Morane Saulniery N nebyly příliš oblíbeny pro složitou pilotáž. Při testech s ukořistěným Fokkerem E.III se ale prokázalo, že Fokker mírně zaostává prakticky ve všech parametrech. Právě Morane Saulniery N začaly ničit mýtus údajně nepřekonatelých Fokkerů E.III.

Technická data:

Rozpětí : 8,15 m, Délka: 5,83 m.

Max. rychlost: 144 km/h, dostup: 4000 m, vytrvalost: 1,5 hod.

(GB)

Designed as a racer and sports aircraft the Morane Saulnier N was test flown in May 1914 just before the outbreak of the First World War. The first public appearance plane meeting held between 21st and 28th June 1914 on Aspern airport in Vienna. Here, Roland Garros the famous pilot won the race in climbing.

When the war broke out the Type N wasn't supposed to become a combat plane. Not until Roland Garros was being shot down, (flying in Morane Saulnier L) his friend Eugene Gilbert committed the Type N prototype to be equipped with non-synchronized Hotchkiss machine gun. Two bullet deflectors were mounted to the propeller. This arrangement was successful and so the Aviation Militaire had ordered small batch of Morane Saulnier N aircraft. These aircraft were assigned to several Escadriles since summer 1915. Mainly Jean Navarre (MS.12) and Adolphe Pegoud (MS.49) were the pilots who brought fame to the Type N aircraft.

In the beginning of 1916 the British RFC ordered a batch of Morane Saulnier N equipped with Lewis machine gun. RFC assigned them to the 1st, 3rd and 60th Squadrons. These aircraft participated in actions over Somme and Cambrai. Later on, they were put out of service due to the lack of spare parts.

Thanks to its intricate piloting the Morane Saulnier Ns were not popular. Comparing test flights with Fokker E.III had proven that Fokker fell short in almost all aspects behind Morane Saulnier N. That was just the Morane Saulnier N, which started to break the myth of the allegedly invincible Fokker E.III aircraft.

Technical specifications:

Wing Span: 8,15m, Length: 5,83m.

Max. Speed: 144 Kph, Ceiling: 4000m, Endurance: 1,5h

DÍLY - PARTS - TEILE - PIECES

PLASTIC PARTS (A,B,D)

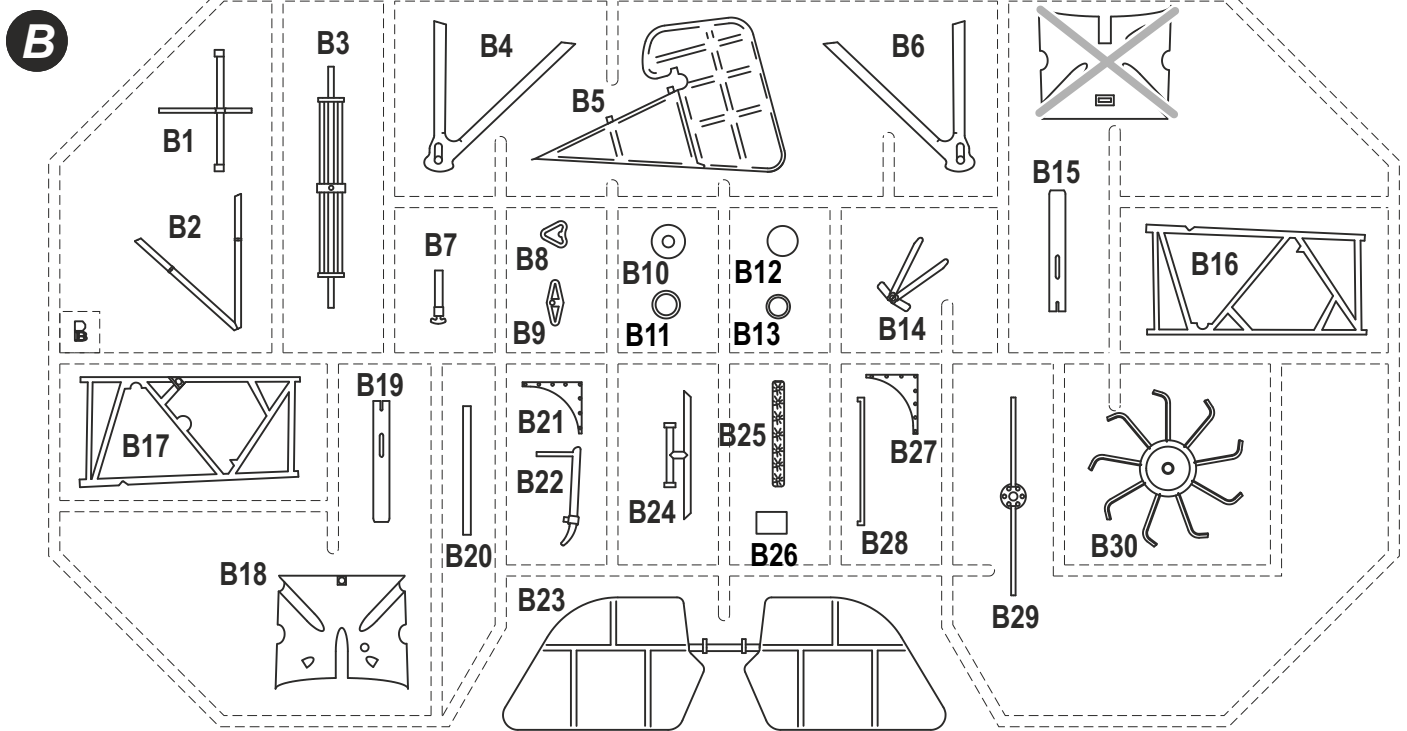
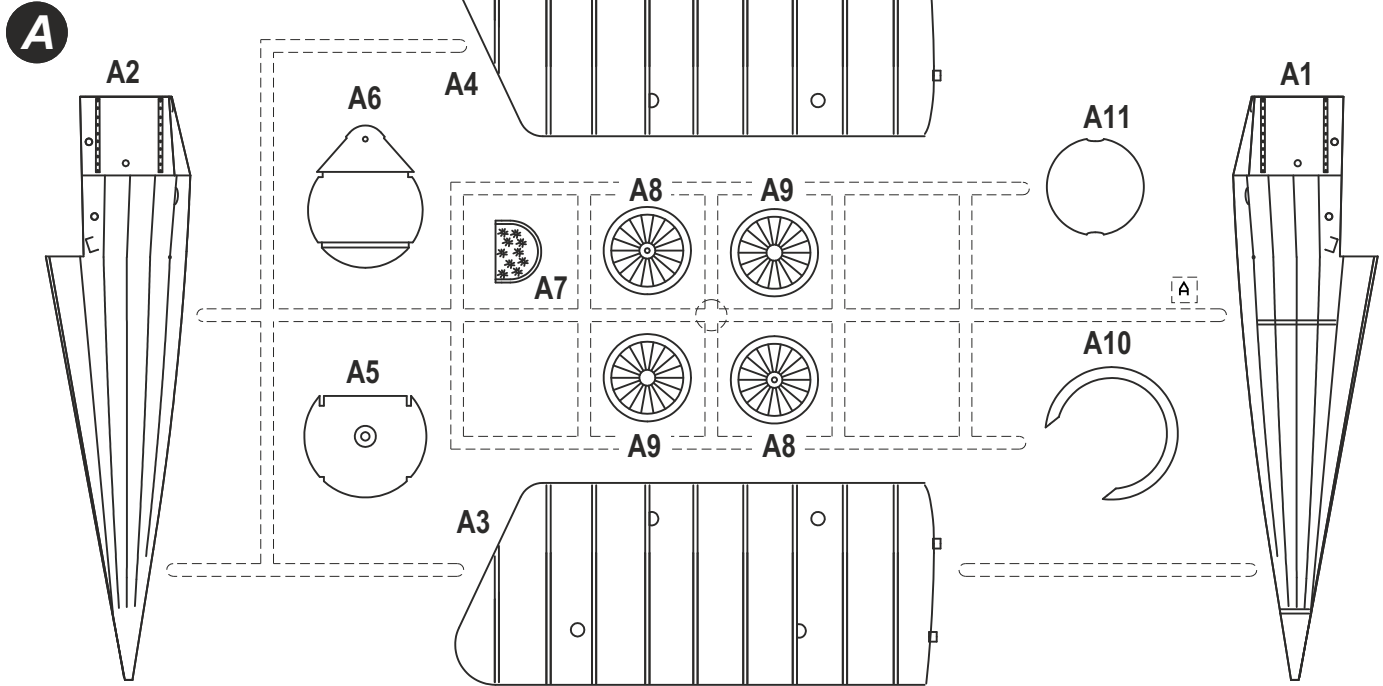

PHOTOETCHED PARTS (PP)

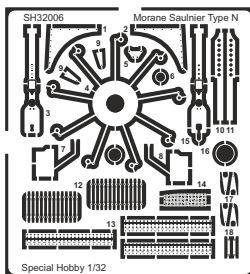

CLEAR PART (F)



FILM

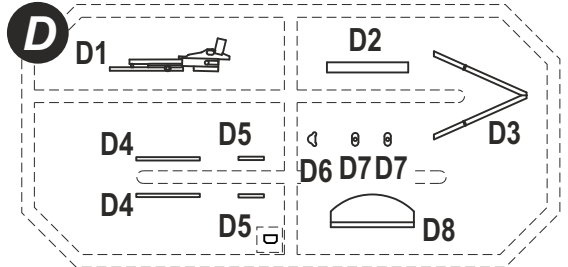

SYMBOLS



Možnost volby
Optional
Nach belieben
Option



Ohnout
Bend
Biegen
Courber



Vyrobít nově
Scratch build
Fertigstellen
Achever



Lepidlo na kov
Glue for metal
Metallkleber
Colle a metal

POLYURETHAN PARTS (E)

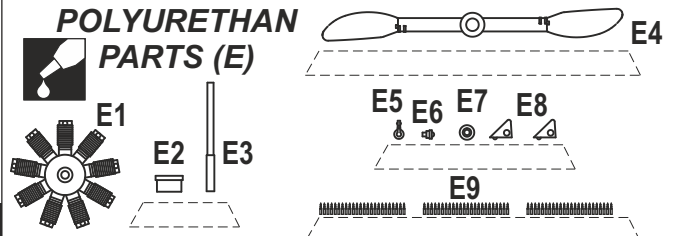

SESTAVA - ASSEMBLY - BAUANLEITUNG-ASSEMBLAGE

1

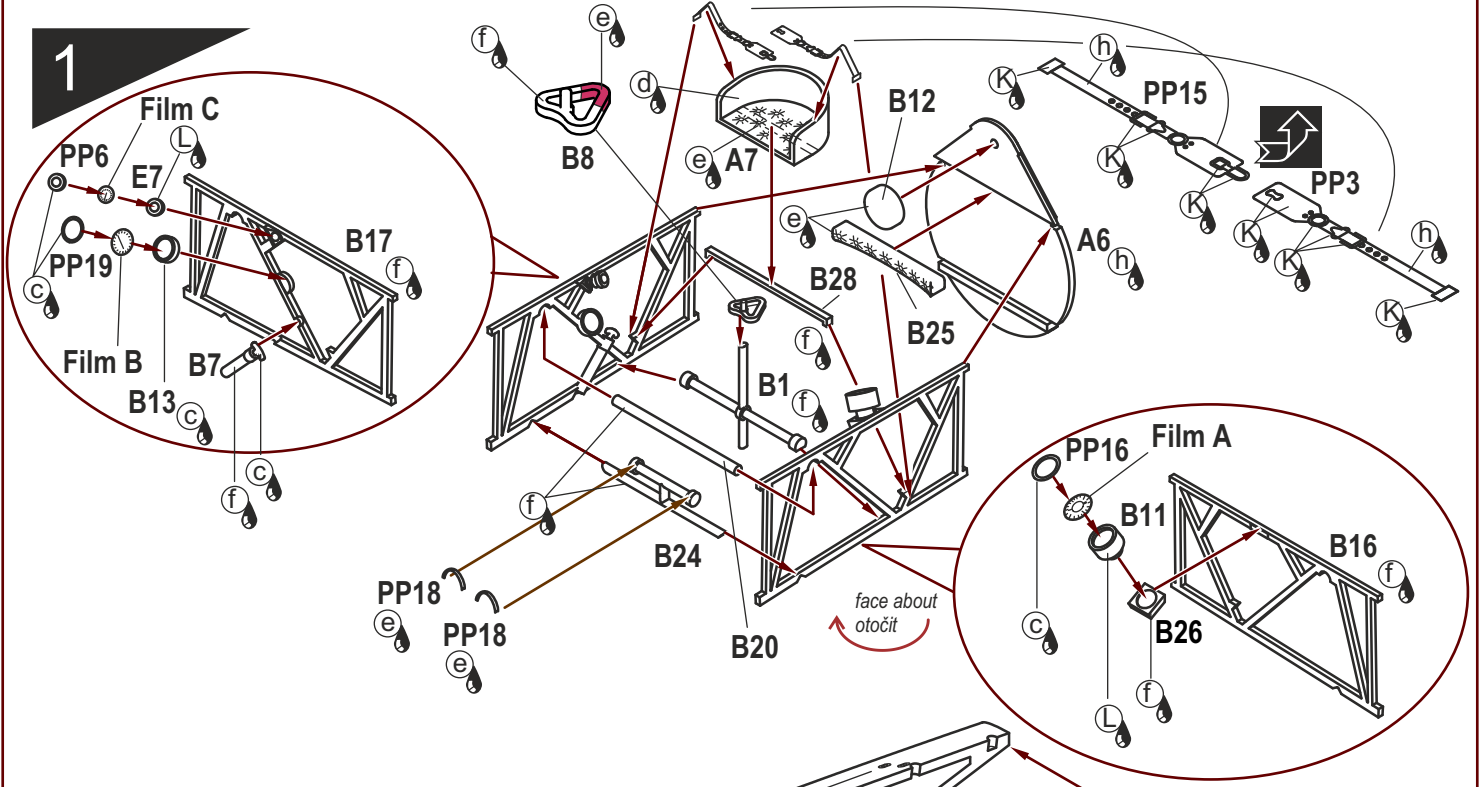

2

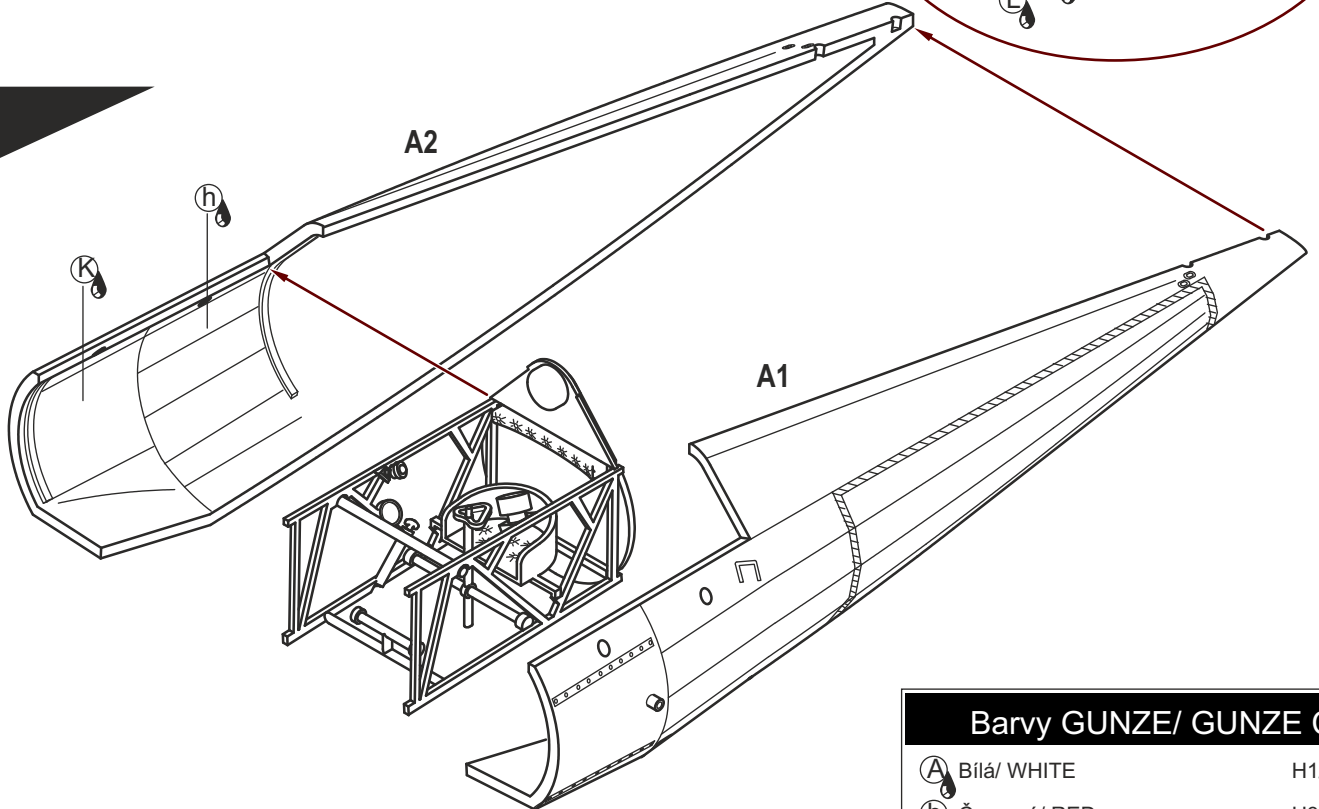

2a

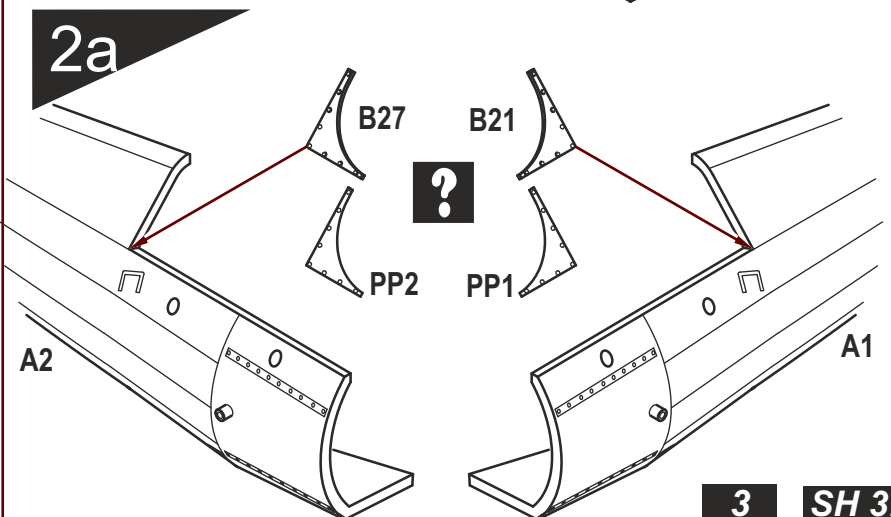

Bary GUNZE/ GUNZE Color

(A)	Bílá/ WHITE	H1/C1
(b)	Červená/ RED	H3/C3
(c)	Černá/ BLACK	H12/C33
(d)	Dřevo/ WOOD BROWN	H37/C43
(e)	Hnědočervená/ RED BROWN	H47/C41
(f)	Šedá/ GREY	H51/C11
(g)	Šedá/ GREY	H53/C13
(h)	Plátno/Linen	H85/C45
(i)	Chrom/ CHROM SILVER	MC211
(j)	Tmavý kov/ DARK IRON	MC214
(K)	Hliník/ ALUMINIUM	MC218
(L)	Mosaz/ BRASS	MC219

3

SH 32006

Morane-Saulnier Type N

SESTAVA - ASSEMBLY - BAUANLEITUNG- ASSEMBLAGE

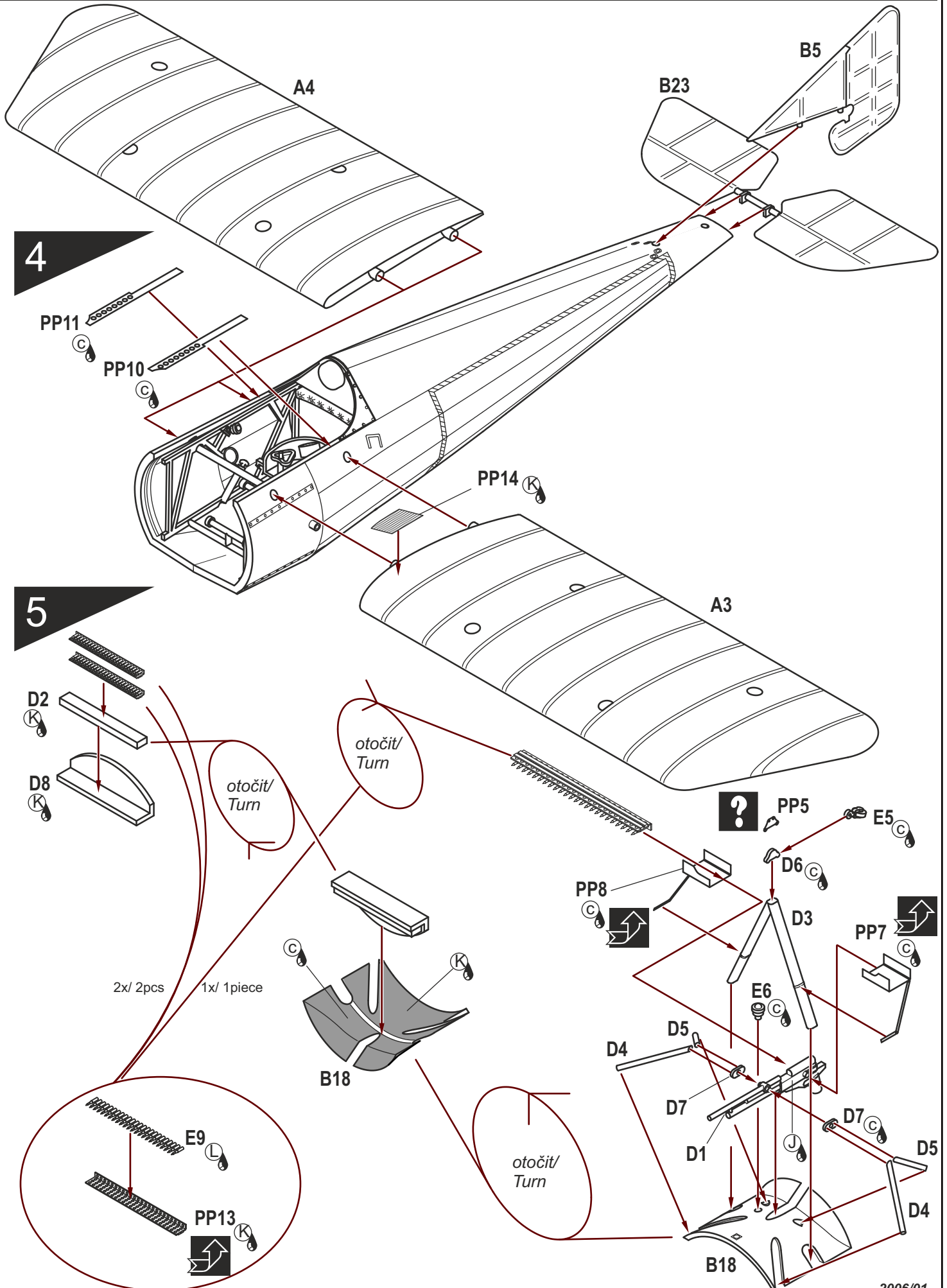

6

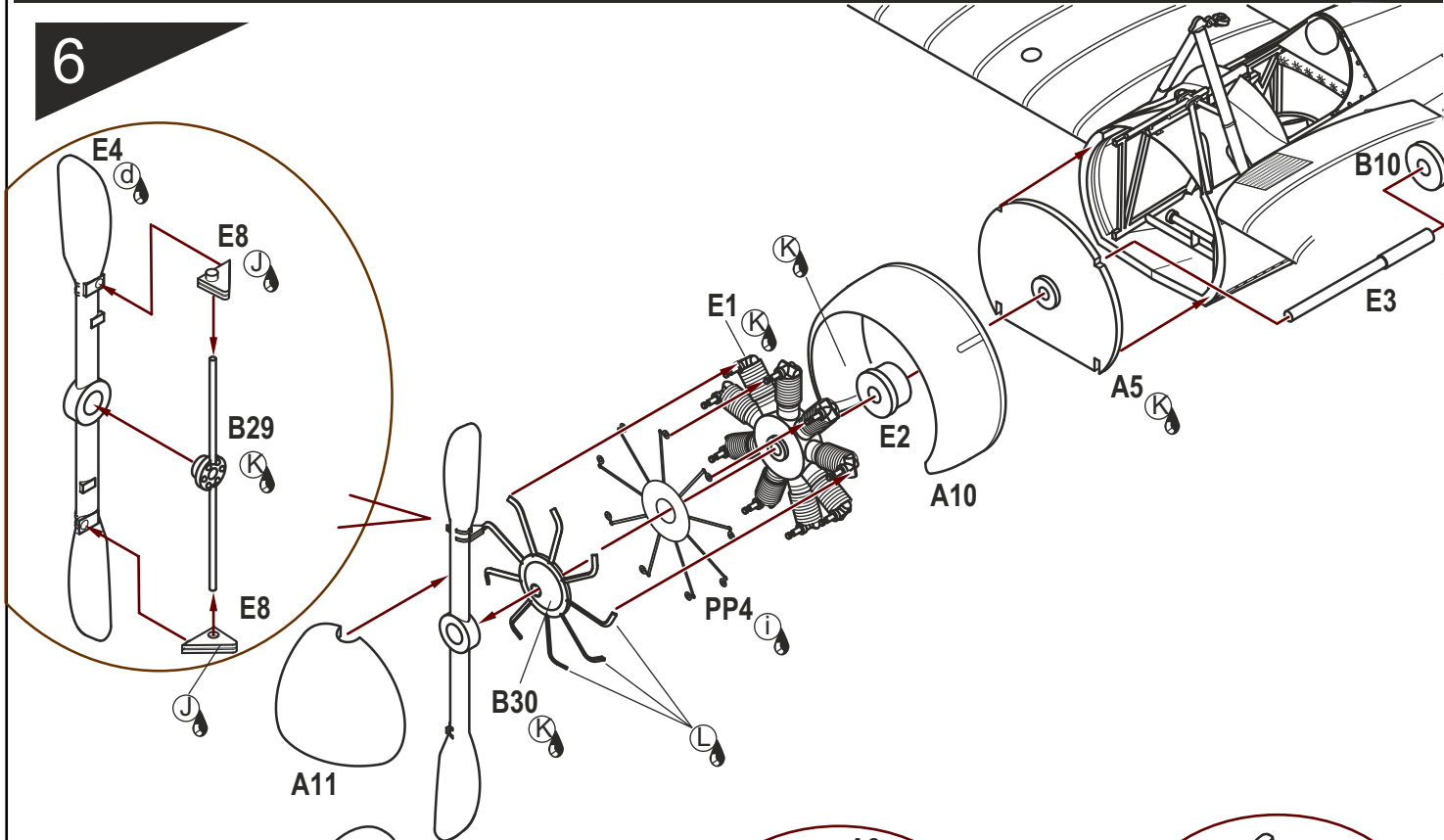

7

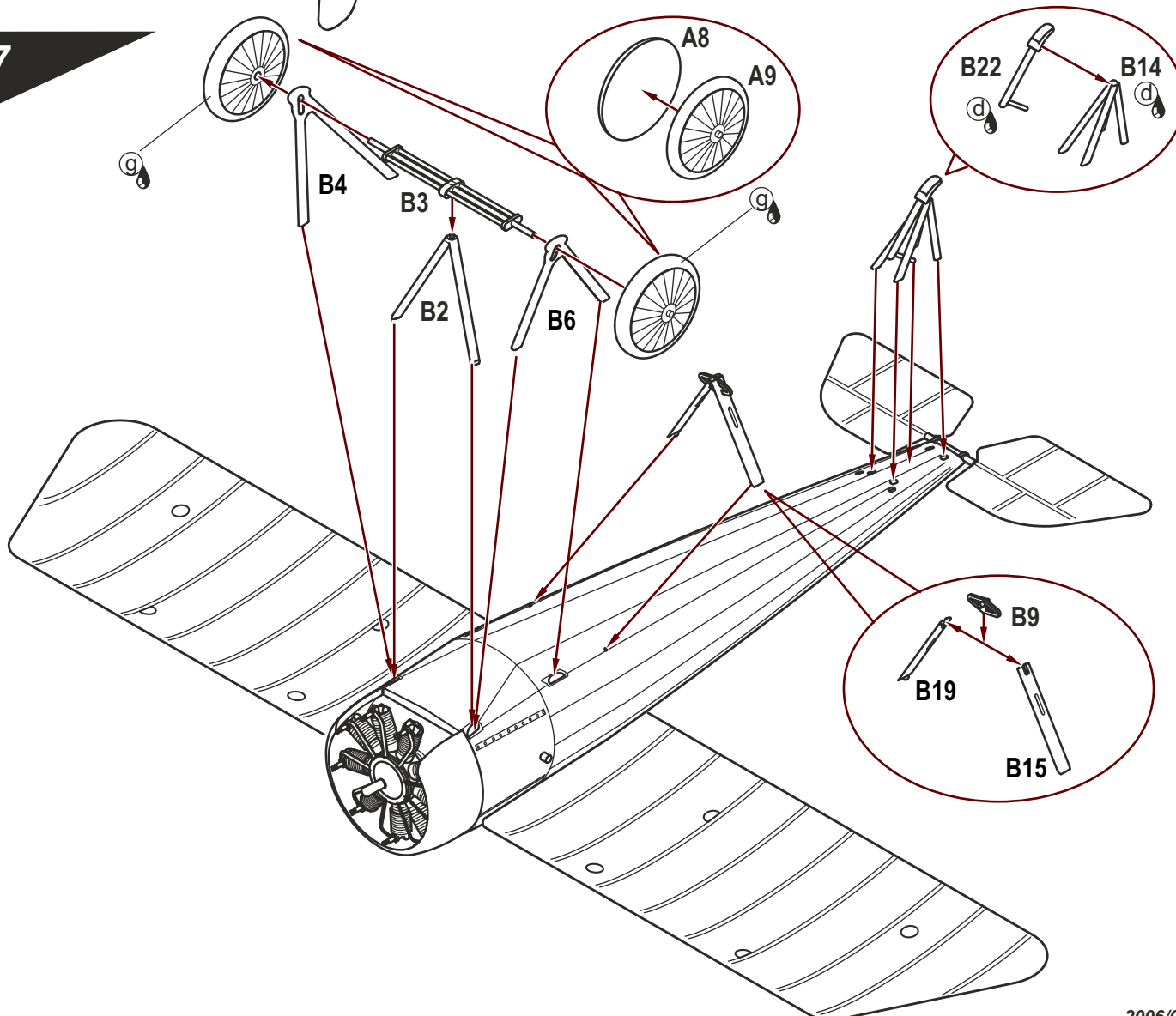

8

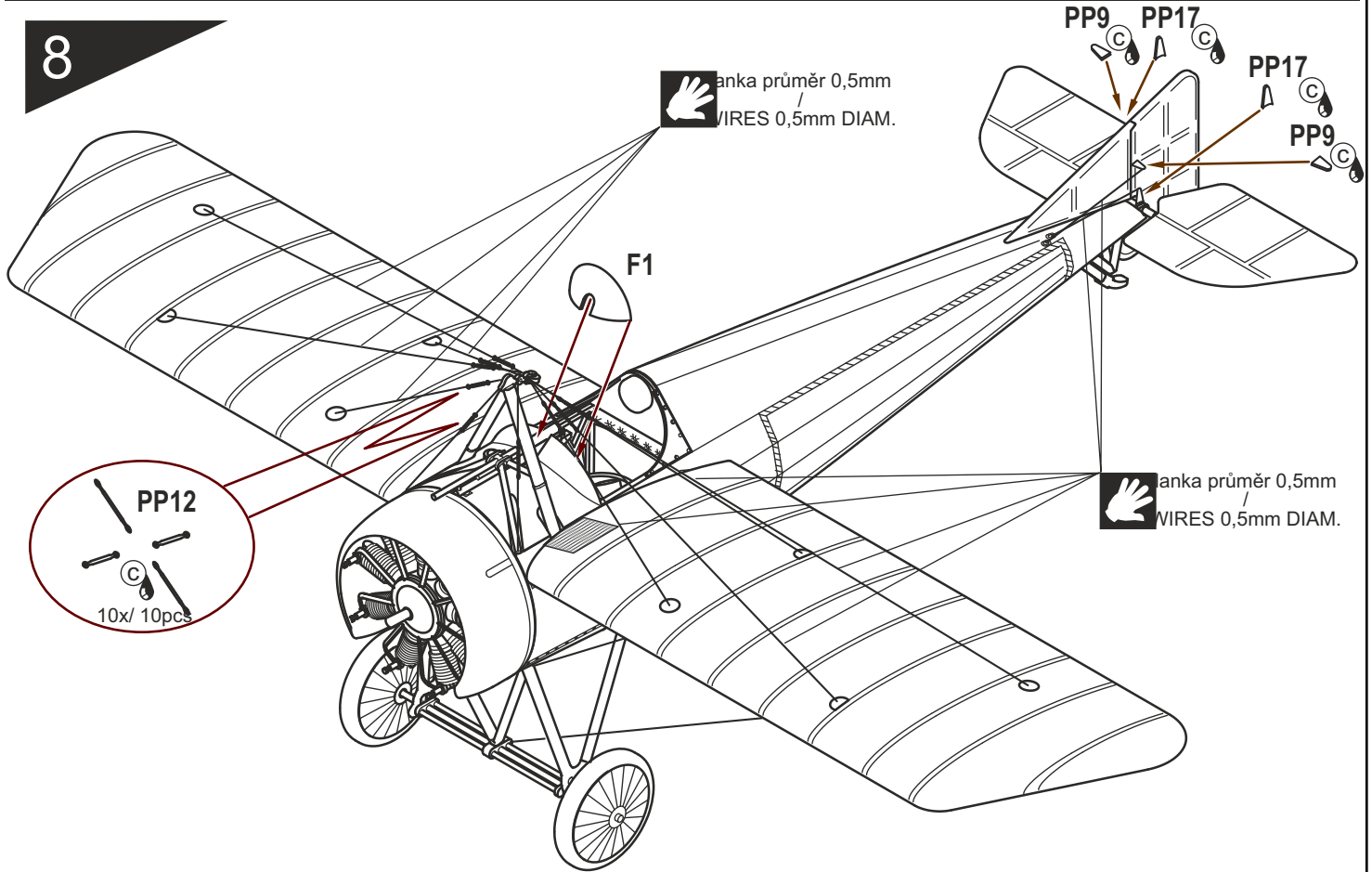

9

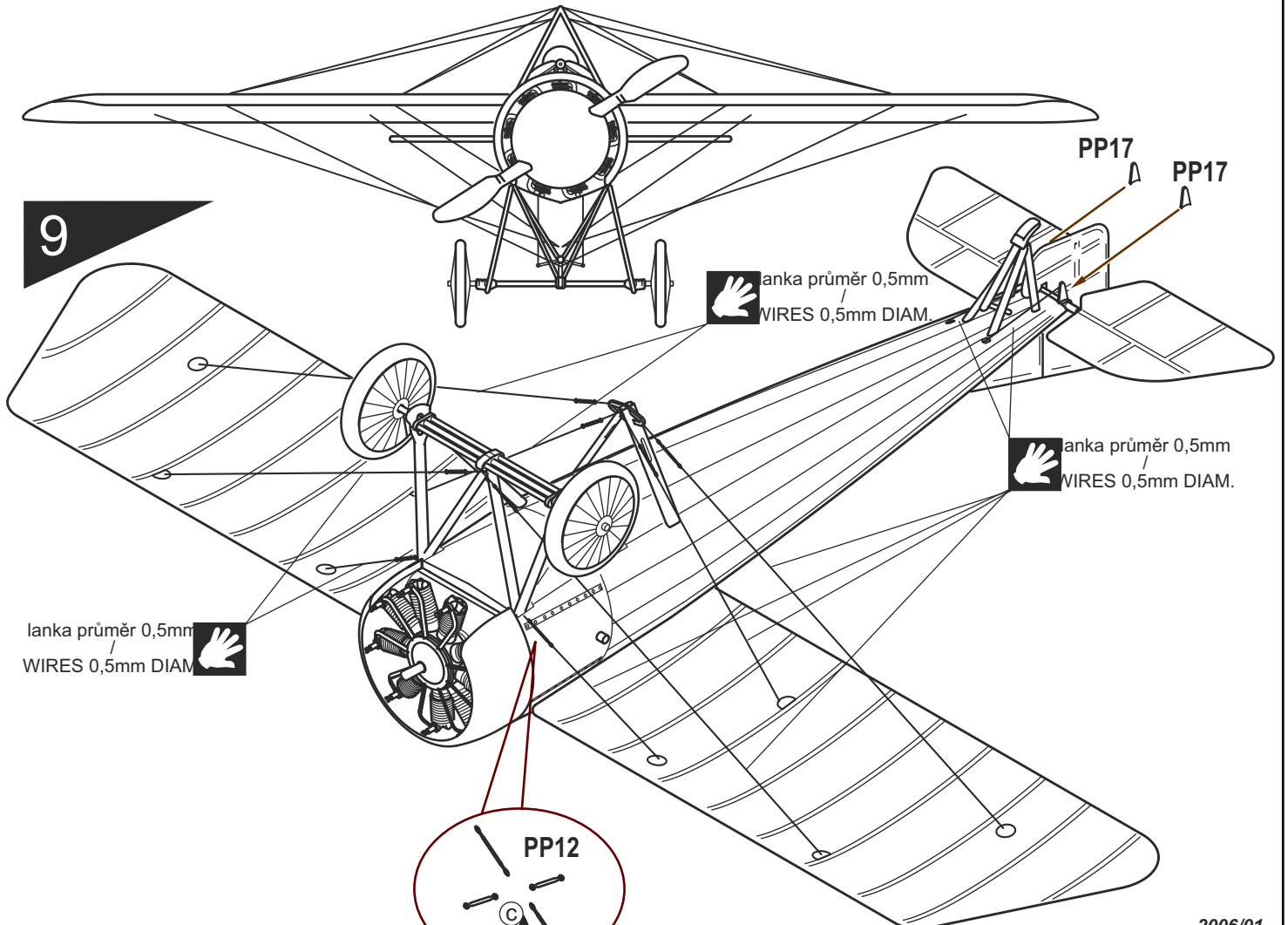

6

SH 32006

Morane-Saulnier Type N

2006/01

ZBARVENÍ A OZNAČENÍ - CAMOUFLAGE AND MARKING

A
camo

MS 394, pravděpodobně z Escadrile MS.12, 1915

MS 394, probably Escadrile MS.12, 1915

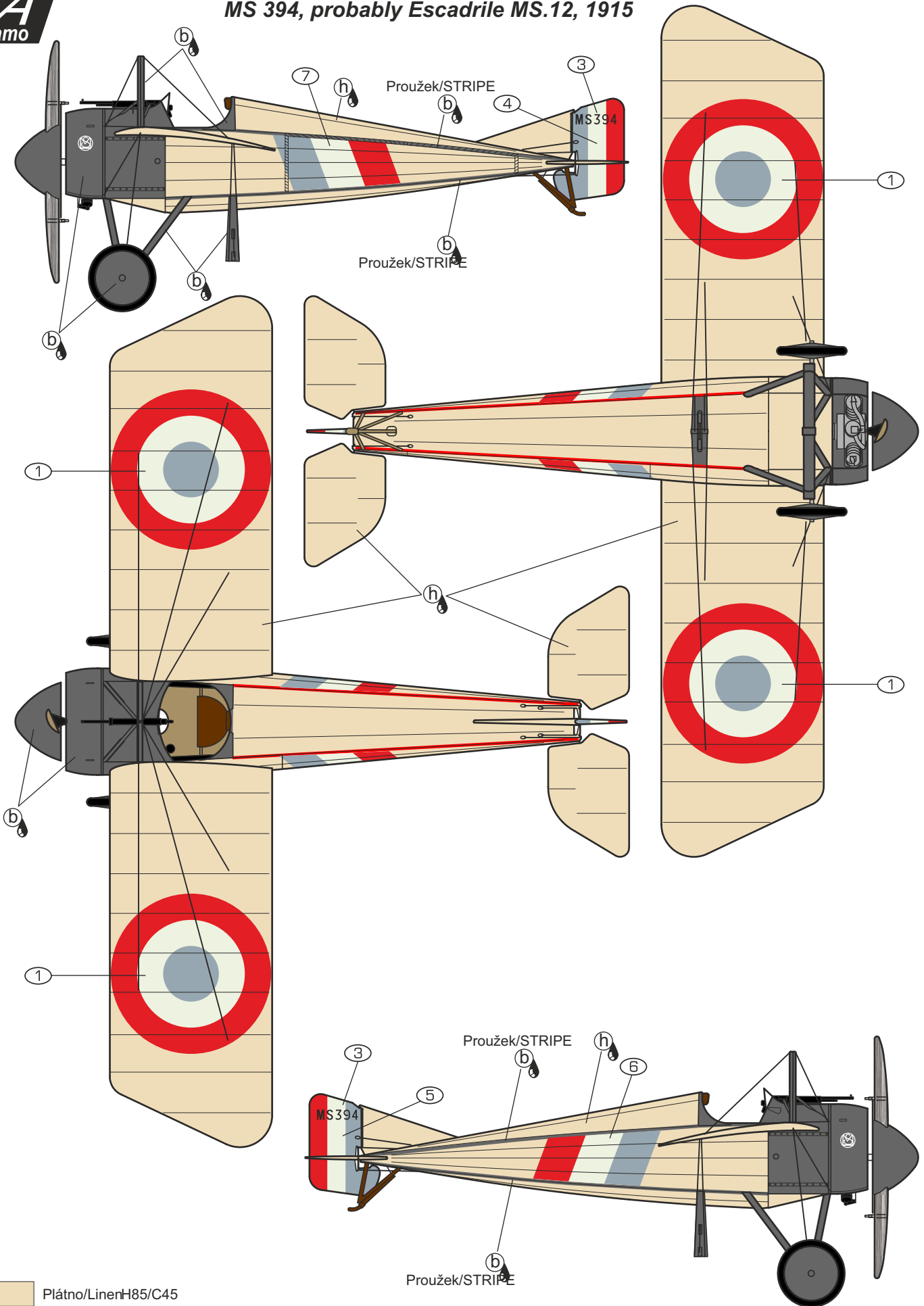

- (h)** Plátno/Linen H85/C45
- (b)** Červená/RED/C3

ZBARVENÍ A OZNAČENÍ - CAMOUFLAGE AND MARKING

B
camo

MS 391, Dunkerque, jednotka ani datum nejsou známy.
MS 391, Dunkerque, neither unit nor date are known.

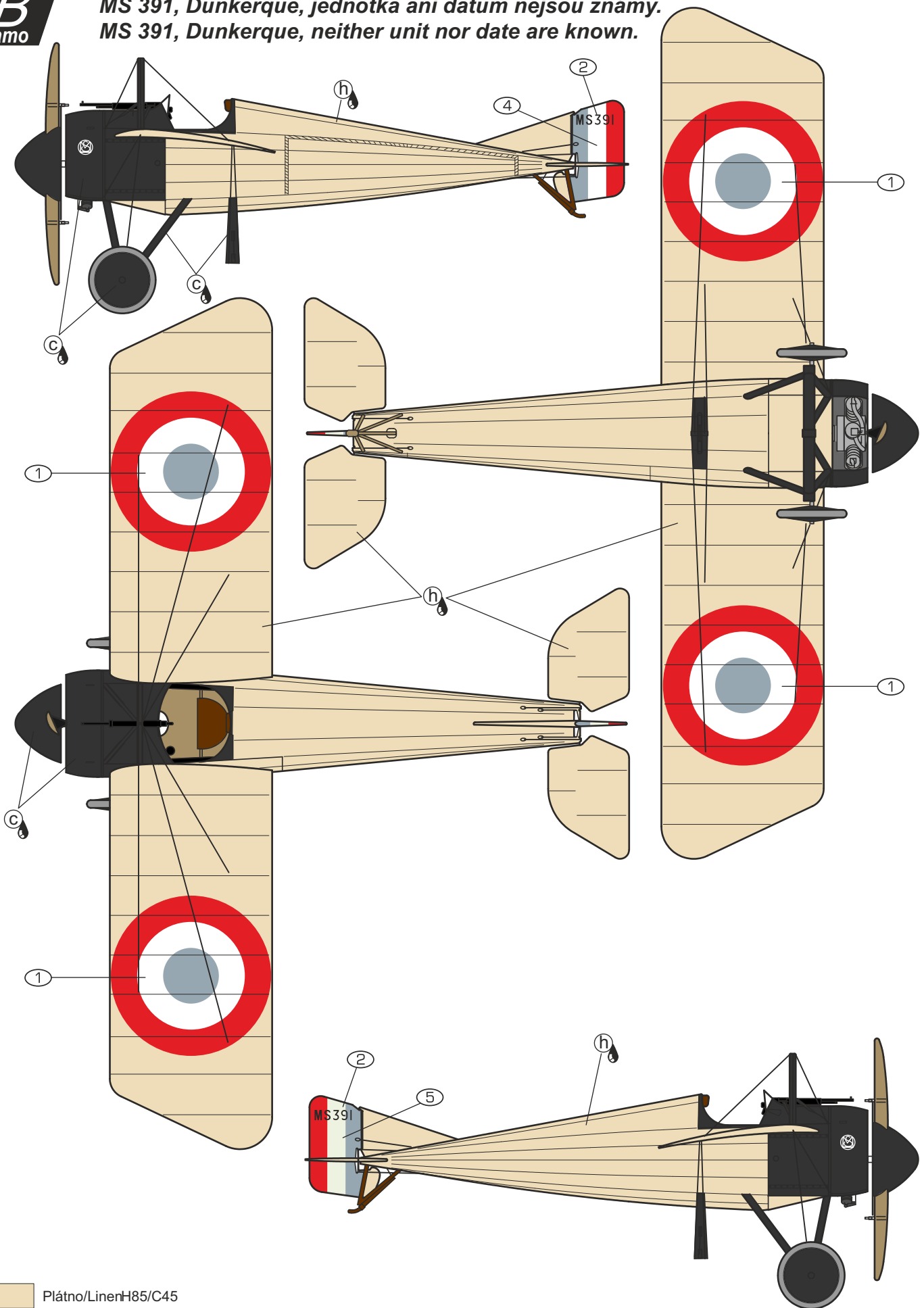

- h Plátno/LinenH85/C45
- c Černá/ BLA#2/C33